

# PRECEPT™

## Technique Guide

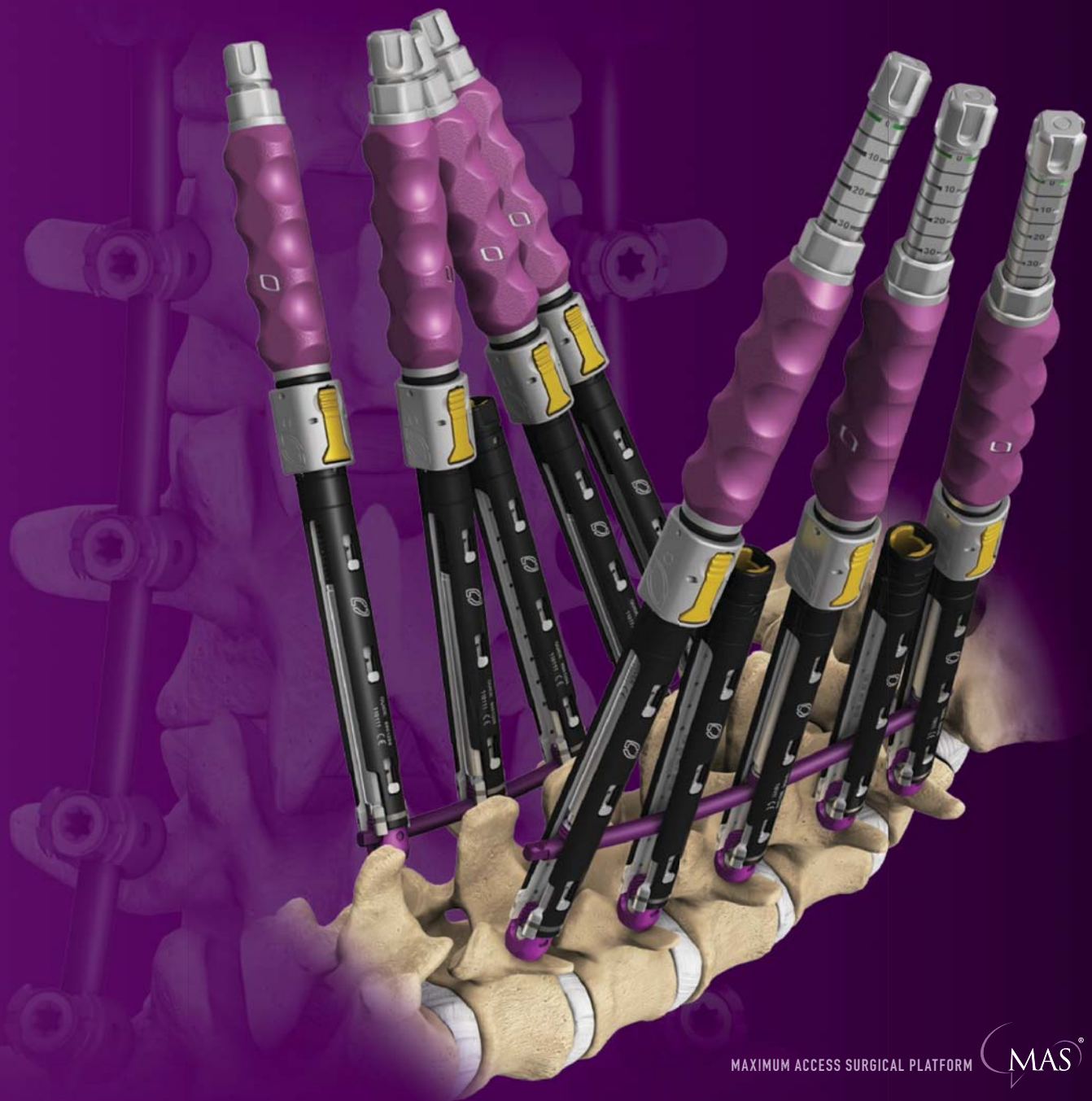

## CONTENTS

Preface	1
<b>Precept™ Core Technique</b>	<b>4</b>
Equipment Requirements	4
Patient Positioning and O.R. Setup	4
Target and Access Pedicles	5
Insert Fascial Splitter (Optional)	8
Facet Preparation (Optional)	9
Insert Dilators	10
Pilot Hole Preparation	11
Tap-Dilator Combo (Optional)	12
Guide Engagement to the Pedicle Screw	13
Screw Insertion	14
Slip-on Guide Engagement to the Pedicle Screw	15
Rod Measurement	16
Rod Insertion	17
Lock Screw Insertion	19
Reduction (Optional)	20
Compression/Distraction (Optional)	24
Final Tightening	26
Guide Removal	27
Slip-on Guide Removal	28
Implant Removal	29
NVM5® Seamless Procedural Integration	30
Dynamic Screw Test	30
Free Run EMG	30
<b>Precept Reduction Screw Technique</b>	<b>34</b>
Screw Insertion	34
Rod Measurement	34
Rod Insertion	35
Lock Screw Insertion	35
Reduction Attachment (Top Hat)	36
“Pile Driver”/“Pistol” Grip Reduction (Optional)	36
Compression (Inline Compressor)	37
Final Tightening	37
Reduction Screw Splitting	38
Extended Tab Break-off	38
<b>Precept System</b>	<b>42</b>
<b>Catalog</b>	<b>54</b>
<b>Instructions for Use</b>	<b>59</b>

## PREFACE

Fellow Colleagues:

With the growing prevalence of minimally disruptive spine surgery, Precept™ is the next evolution in posterior pedicle screw fixation. Precept provides surgeons with unprecedented power to treat a wide range of pathologies from the simple to the complex, all while maintaining unparalleled ease-of-use. It is designed to be simple and consistent for all users. This comprehensive instrumentation set and implant options delivers the very latest in tissue-sparing technology.

We, the Precept designers, believe that you will find Precept to be the premier system in delivering exemplary care to your patients.

Cordially,



James Billys, M.D.  
Clinical Professor USF  
Department of Orthopaedics  
Florida Orthopaedic Institute  
Tampa, FL



Christopher Brown, M.D.  
Division of Orthopaedic Surgery  
Duke University Medical Center  
Durham, NC

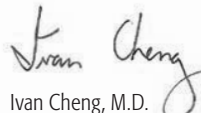

Ivan Cheng, M.D.  
Department of Orthopaedic Surgery  
Stanford University  
Stanford, CA

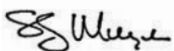

S. Craig Meyer, M.D.  
Orthopaedic Spine Surgery  
Columbia Orthopaedic Group  
Columbia, MO



Jeffrey D. Coe, M.D.  
Orthopaedic Spine Surgery  
Silicon Valley Spine Institute  
Campbell, CA

PRECEPT™ CORE TECHNIQUE



# PRECEPT™ CORE TECHNIQUE

## PRECEPT™ CORE TECHNIQUE

### EQUIPMENT REQUIREMENTS

- C-Arm Fluoroscope
- I-PAS™ III Needle
- Radiolucent Surgical Table
- NVM5® System
- Precept™ Spinal System

### STEP 1:

#### PATIENT POSITIONING AND O.R. SETUP

Place the patient on the operating table in a prone position. Prepare and drape in a conventional manner. The fluoroscope should have easy access to the surgical field for both A/P and lateral views. Uniplanar or biplanar fluoroscopy may be used. Fluoroscopic monitors and the NVM5 unit should be placed in clear view (*Fig. 1*).

For a complete list of intended uses, indications, device description, contraindications, warnings, and precautions, please refer to the Instructions for Use (IFU) in the back of this technique guide.



(Fig. 1)

## PRECEPT™ CORE TECHNIQUE

### STEP 2: TARGET AND ACCESS PEDICLES

Using A/P fluoroscopy, place a K-Wire longitudinally along the lateral margins of the targeted pedicles (Figs. 2, 3). Move the K-Wire laterally 1-3cm, depending on the size of the patient, and mark the skin along the K-Wire. Place the K-Wire perpendicular to the longitudinal line over the center of the pedicle (Figs. 4, 5) and mark the skin. The intersection of the two lines represents the skin incision location and entry point for the I-PAS™ III needle.

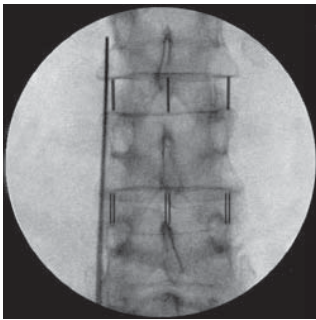

(Fig. 2)

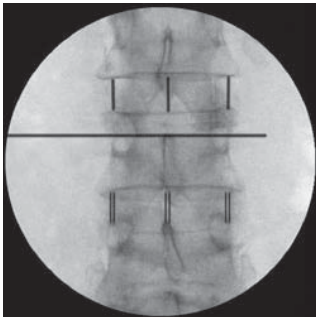

(Fig. 4)

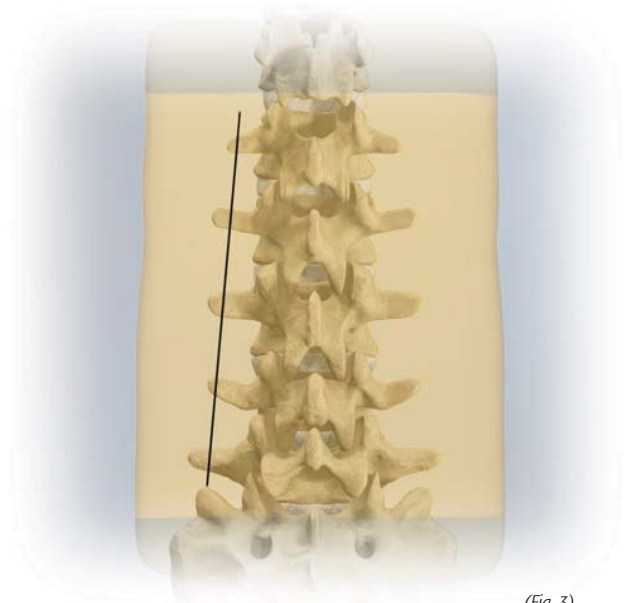

(Fig. 3)

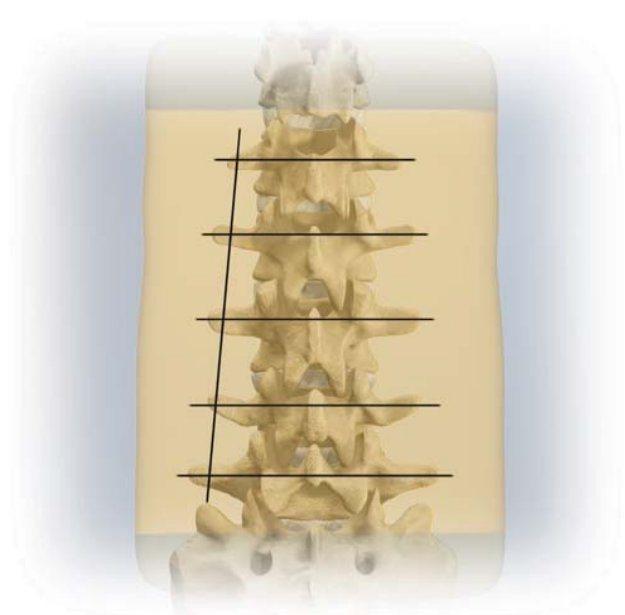

(Fig. 5)

PRECEPT™ CORE TECHNIQUE

**STEP 2:  
TARGET AND ACCESS PEDICLES (CONT.)**

Make a 2cm skin incision at the intersection of the two previously drawn lines. With the NVM5<sup>®</sup> Dynamic Stimulation Clip attached, initiate NVM5 Dynamic Stimulation Mode and insert the I-PAS™ III needle through the incision. Advance the tip down to the transition of the transverse process and facet joint (Fig. 6). Using A/P fluoroscopy, verify the needle is positioned slightly superior and lateral to the center of the pedicle (Fig. 7). Insert the tip of the I-PAS III needle a few millimeters into the bone to secure its position. Prior to advancing into the pedicle, use lateral fluoroscopy to verify that the trajectory follows a line through the pedicle (Fig. 8). With an oblique trajectory, advance the I-PAS III needle into the pedicle. Continue to pass the needle using a combination of fluoroscopy and NVM5 for guidance. Remove the I-PAS III stylet and introduce a K-Wire through the cannulation, leaving approximately 1cm of the K-Wire extending into the vertebral body (Fig. 9). Remove the I-PAS III needle, leaving the K-Wire in position.

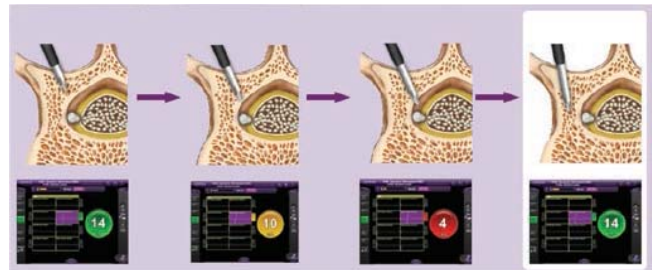

(Fig. 6)

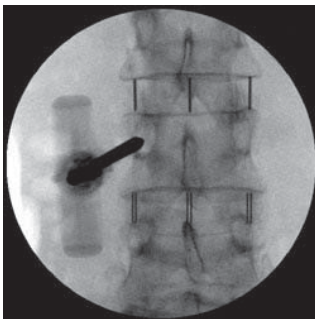

(Fig. 7)

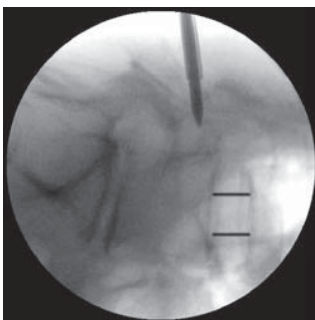

(Fig. 8)

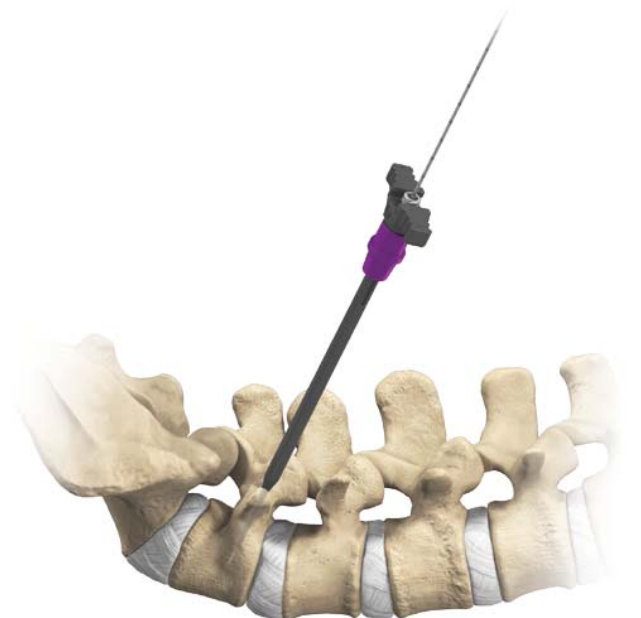

(Fig. 9)



## PRECEPT™ CORE TECHNIQUE

**STEP 2:  
TARGET AND ACCESS PEDICLES (CONT.)****OPTIONAL**

The K-Wire Driver may be used to advance or remove the K-Wire, as needed, throughout the procedure. Begin by opening the inner cannulation of the driver by depressing the lever on the body of the driver and introducing the driver over the K-Wire (*Fig. 10*).

Once the desired position on the K-Wire is reached, release the lever to secure the driver in position. Use the integrated slap hammer to either advance **A** or remove **B** the K-Wire, using lateral fluoroscopy to monitor depth.

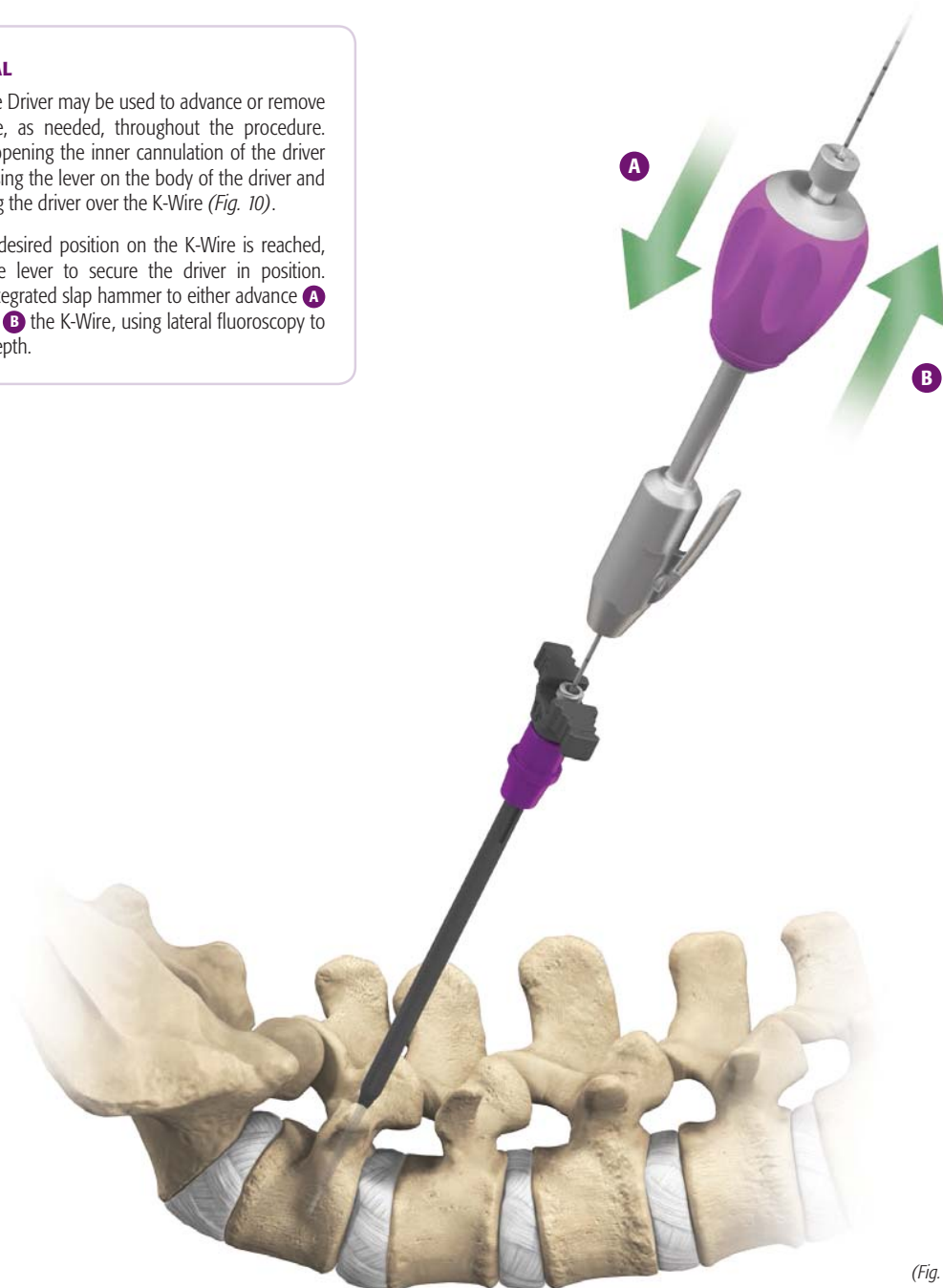

(Fig. 10)

PRECEPT™ CORE TECHNIQUE

**STEP 3:**  
**INSERT FASCIAL SPLITTER (OPTIONAL)**

Remove the I-PAS™ III needle and leave the K-Wire in place (Fig. 11). Using a scalpel, ensure the skin incision has been optimized to the blade dimensions of the Fascial Splitter Handle.

**Loading**

Open the disposable fascial splitter blade and hold the plastic tip. Thread the Fascial Splitter Handle by rotating the proximal gold knob clockwise (keeping slight axial downward force) until the blade is fully secured, and the gold knob no longer rotates (Fig. 12). Remove the plastic protective tip, as the blade is ready for use.

Slide the distal tip of the blade over the K-Wire via the cannulation and create a path through the fascia (Fig. 13). Once an adequate path has been created, remove the blade from the surgical site. Repeat this step over the remaining K-Wires/screw insertion sites.

**Removal**

On the back table, remove the disposable fascial splitter blade by turning the proximal gold knob counterclockwise until the blade is no longer secured to the handle (Fig. 13). Dispose of the fascial splitter blade according to proper sharps protocol.

**NOTE**

The fascial splitter blade is 17.2mm wide and is not used to cut skin – only to clear a path through the fascia.

**CAUTION**

Ensure the K-Wire is not advancing as the path is created over the K-Wire.

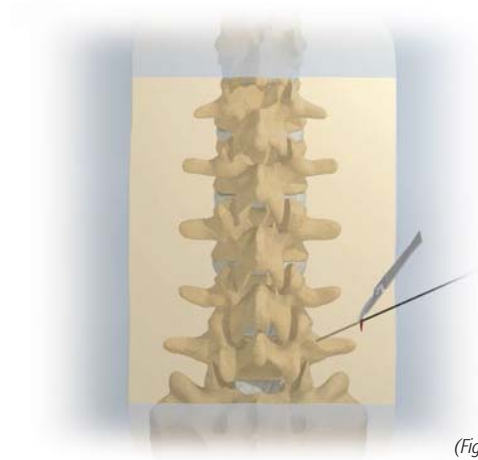

(Fig. 11)



(Fig. 12)

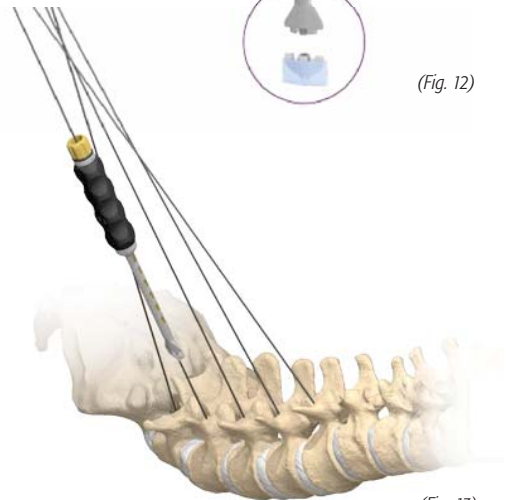

(Fig. 13)

## PRECEPT™ CORE TECHNIQUE

### STEP 3: FACET PREPARATION (OPTIONAL)

Locate the K-Wire Channel on the side of the Facet Tube, directly across from the light source track. Properly orient the K-Wire Channel to capture the K-Wire. Advance the Facet Tube and Facet Tube Dilator down to the facet capsule (Fig. 14).

Upon confirmation of proper Facet Tube placement, remove the Facet Tube Dilator and insert the light source into the light source track to enhance visualization (Fig. 15). Decorticate and place graft material, as needed.

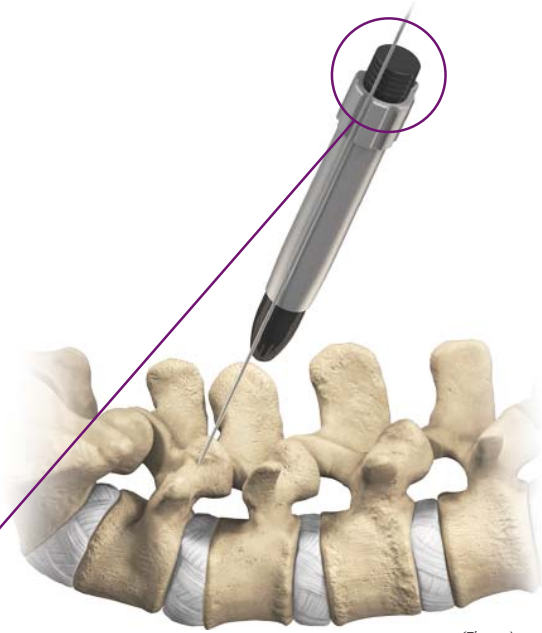

(Fig. 14)

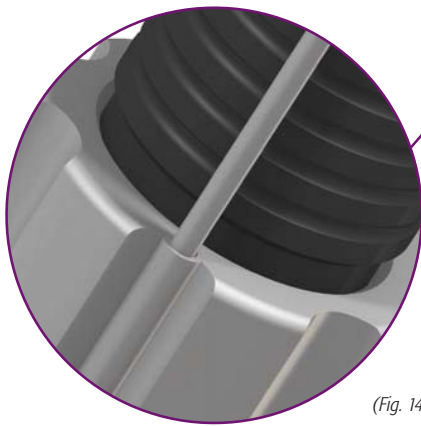

(Fig. 14a)

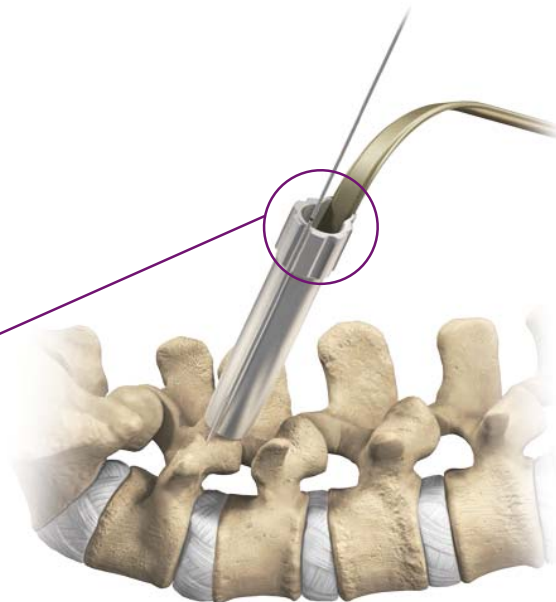

(Fig. 15)

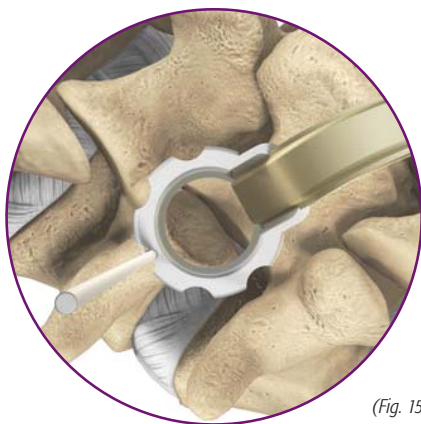

(Fig. 15a)

PRECEPT™ CORE TECHNIQUE

**STEP 4:  
INSERT DILATORS**

**NOTE**

Prior to inserting the Primary Dilator, the fascial splitter may be used to optimize the skin incision.

Introduce the Primary Dilator over the K-Wire and advance to the pedicle. Precept™ dilators are radiodense, enabling their position to be verified fluoroscopically. Sequentially dilate with the Tap and Screw Dilators, ensuring all dilators are fully seated onto bone (Fig. 16).



(Fig. 16a)

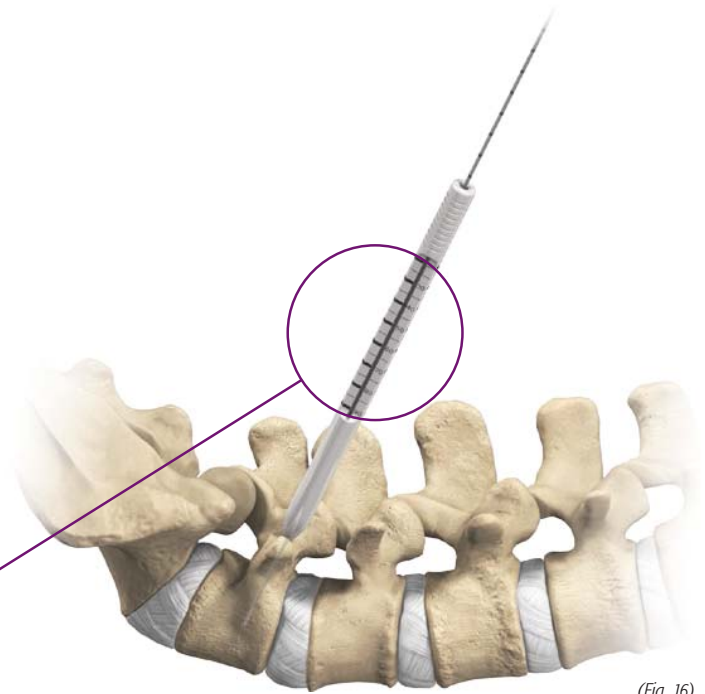

(Fig. 16)

**OPTIONAL**

**Screw Shank Measurement Technique**

Advance the K-Wire to the desired screw shank depth. The appropriate screw shank is estimated by the intersection of the most distal laser mark on the K-Wire and window of the dilator (Fig. 17).

**CAUTION**

Use lateral fluoroscopy to properly manage the K-Wire during pedicle preparation to ensure proper placement and avoid anterior advancement of the K-Wire.



(Fig. 17)

## PRECEPT™ CORE TECHNIQUE

### STEP 5: PILOT HOLE PREPARATION

Remove the Primary Dilator, leaving the K-Wire, Tap Dilator, and Screw Dilator in position. Attach the NVM5® Dynamic Stimulation Clip to the Dynamic Stimulation Ring below the handle of the appropriate Tap. Initiate NVM5 Dynamic Stimulation mode (Fig. 18) and tap to the desired depth (Fig. 19).

#### NOTE

The thread length is 40mm and can be used as a reference when determining screw length. In addition, the depth markings on the Tap, as measured from the top of the Tap Dilator, can also be used to estimate screw length.

#### CAUTION

Use lateral fluoroscopy to properly manage the K-Wire during pedicle preparation to ensure proper placement and avoid anterior advancement of the K-Wire.

#### Tips and Tricks

Watch lines on K-Wire to help avoid K-Wire advancement or pullout.

#### Tips and Tricks

Tap slightly beyond the posterior wall and into the cancellous bone of the vertebral body to avoid K-Wire advancement and kinking.

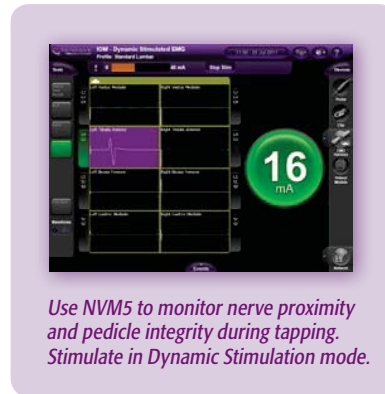

Use NVM5 to monitor nerve proximity and pedicle integrity during tapping. Stimulate in Dynamic Stimulation mode.

(Fig. 18)



(Fig. 19)

PRECEPT™ CORE TECHNIQUE

**STEP 6:**  
**TAP-DILATOR COMBO (OPTIONAL)**

The Tap-Dilator Combo obviates the need to sequentially dilate. Attach a ratcheting handle to the Tap. Press the button on the Tap-Dilator Combo, and pass the Tap through the dilator until it is securely retained (Fig. 20). When the dilator is fully seated onto the bone, press the button on the Tap-Dilator Combo to release the Tap, and tap to the desired depth (Fig. 21).

**CAUTION**

The Screw Dilator cannot be used to sequentially dilate around the Tap-Dilator Combo. Therefore, the screw will be inserted without a dilator.

**NOTE**

The depth markings on the Tap, as measured from the top of the Tap-Dilator Combo, can also be used to estimate screw length (Fig. 21a).



(Fig. 20)

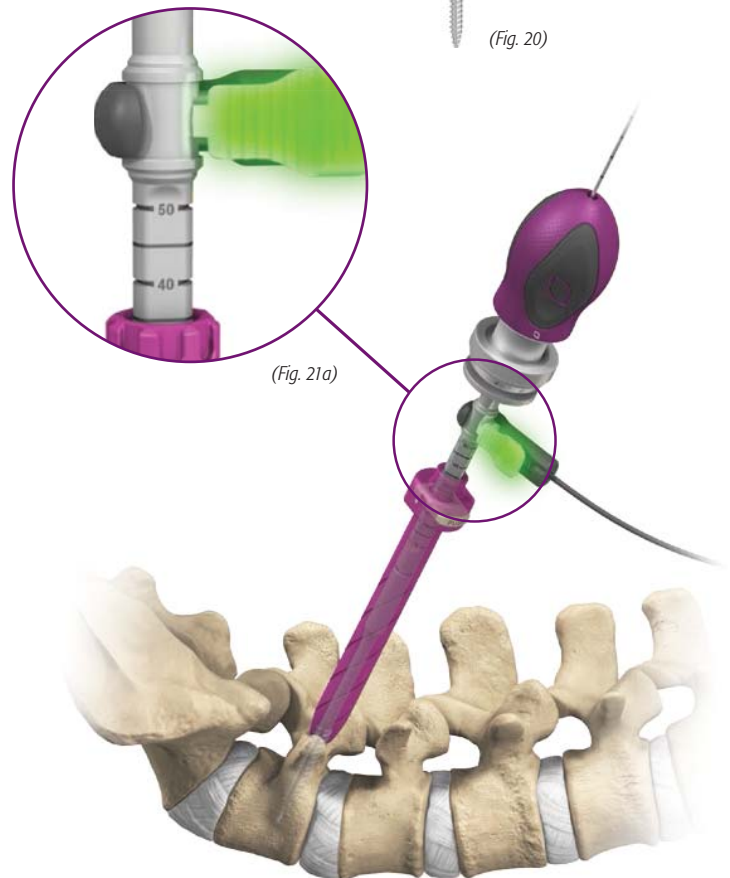

(Fig. 21a)

(Fig. 21)

## PRECEPT™ CORE TECHNIQUE

### STEP 7:

#### GUIDE ENGAGEMENT TO THE PEDICLE SCREW

Place the Guide Locking Cap into the proximal end of the Guide. Turn the Guide Locking Cap counterclockwise until the gold castle nut is completely backed out (Fig. 22).

With the screw in the caddy, align the tulip rod slot with the rod slot on the Guide (Fig. 22a), and then apply downward (axial) pressure until the Guide engages the screw (Fig. 23).

With the screw engaged, turn the Guide Locking Cap clockwise until the gold castle nut sits flush with the proximal end of the Guide (Figs. 23-25).

#### NOTE

Verify proper engagement of the Guide to the pedicle screw in two ways:

1. Ensure the gold castle nut sits flush within the proximal end of the Guide (Fig. 24).
2. Ensure the two black lines on the distal end of the Guide are aligned prior to implanting the screw (Fig. 25).

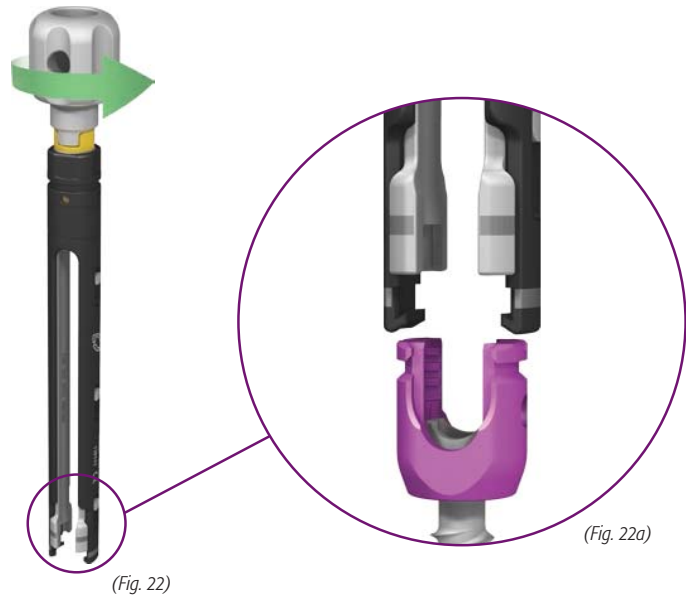

(Fig. 23)

(Fig. 24)

(Fig. 25)

PRECEPT™ CORE TECHNIQUE

**STEP 8:  
SCREW INSERTION**

Attach the Ratcheting Teardrop Handle to the Screwdriver. Insert the Screwdriver through the Guide until the Screwdriver tip engages in the screw shank. Secure the Screwdriver into position by turning the trilobe section clockwise to thread the Screwdriver tip into the screw head (Fig. 26). Prior to screw insertion, confirm the screw shank and Screwdriver are axially aligned.

Remove the Tap-Dilator Combo, leaving the K-Wire and Screw Dilator in position. Attach the NVM5<sup>®</sup> Dynamic Stimulation Clip, and then advance the screw over the K-Wire into the pedicle.

Advance the screw until the tip reaches the posterior wall of the vertebral body. Remove the K-Wire. Continue to advance the screw into the vertebral body until the screw is at desired depth/position (Fig. 27). Release the Screwdriver from the screw head by turning the trilobe section counterclockwise. Once the threads are fully disengaged from the screw head, remove the Screwdriver from the Guide. Remove the Screw Dilator, push down on the Guide, and rotate the Guide in an orbital motion to ensure full polyaxial motion of the screw head is maintained (Fig. 28).

If fine adjustments to screw depth are required, the Screw Adjuster should be used.

**NOTE**

**Ensure the pedicle screw is not driven down so far onto the bone that it prevents full polyaxial motion of the screw head, as this will make rod insertion more difficult.**



(Fig. 26)



Use NVM5 to monitor nerve proximity and pedicle integrity during screw insertion. Use Dynamic Stimulation mode.



(Fig. 27)

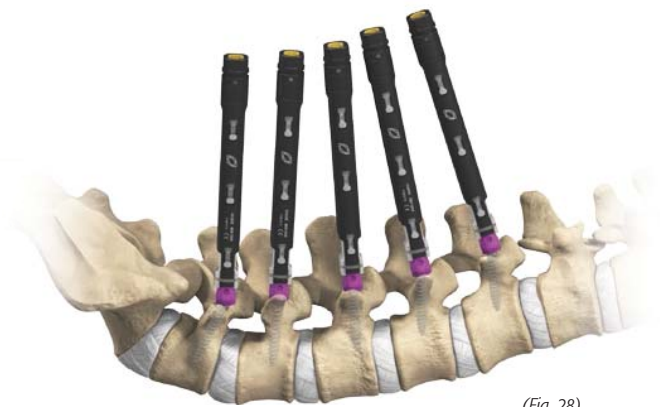

(Fig. 28)



## PRECEPT™ CORE TECHNIQUE

### STEP 9: SLIP-ON GUIDE ENGAGEMENT TO THE PEDICLE SCREW

A Slip-on Guide is available to reattach and positively engage the tulip. The Slip-on Guide can be used as a standard guide for rod manipulation.

Steps for reattachment:

1. Insert the Reattachment Tool into the tulip.
2. Slide the Slip-on Guide over the top of the Reattachment Tool (Fig. 29).
3. Align black lines on Guide and Reattachment Tool; then apply axial pressure until Guide positively engages the tulip (Fig. 29a).
4. Remove the Reattachment Tool (Fig. 30).

#### **Tips and Tricks**

*The Slip-on Guide can also attach to the Reduction Screws, should the Reduction Screw tabs prematurely break.*

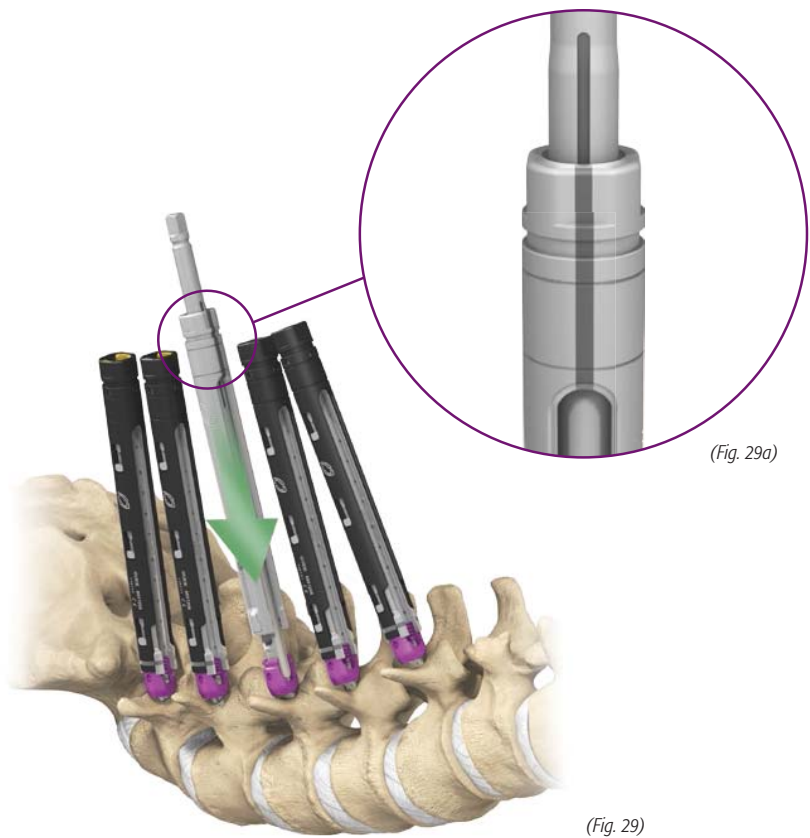

(Fig. 29)

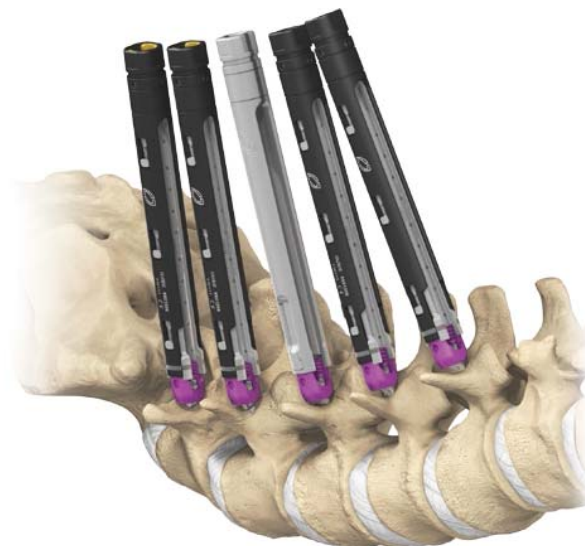

(Fig. 30)

PRECEPT™ CORE TECHNIQUE

**STEP 10:  
ROD MEASUREMENT**

Insert the arms of the Rod Measurement Tool into the proximal ends of the superior and inferior Guides, and advance the arms down into the screw heads (Fig. 31). Full seating of the Rod Measurement Tool is confirmed when the grooves at the top of the arms are positioned at the top of both Guides (Fig. 31a). It may be necessary to angle the Rod Measurement Tool cephalad and caudal to fully seat the distal end of the measurement tool into the screw heads. It is important to note the displayed measurement will indicate the distance between the screw shanks. The surgeon will add length as necessary.

**NOTE**

It may be necessary for the surgeon to add length to the rod, depending upon patient anatomy and desired lordosis. As a general rule, add 15mm. If the measurement is in-between rod sizes, always round up to the next rod length. For long constructs, it may be necessary to add more length.



## PRECEPT™ CORE TECHNIQUE

### STEP 11: ROD INSERTION

Prior to insertion, incise between the Guides. Align the rod slot of the Guides along the rod pathway by utilizing the Guide Adjuster. Clear a rod pathway between the screw heads by inserting the Curved Tissue Dissector into the superior Guide at skin level and advancing the tip down to the screw head. Ensure a clear pathway between the Guides by inserting the Tissue Dissector (Fig. 32).

#### Tips and Tricks

Insert the Rod Pusher into each Guide to tap against the Tissue Dissector to ensure the Dissector is through each Guide.

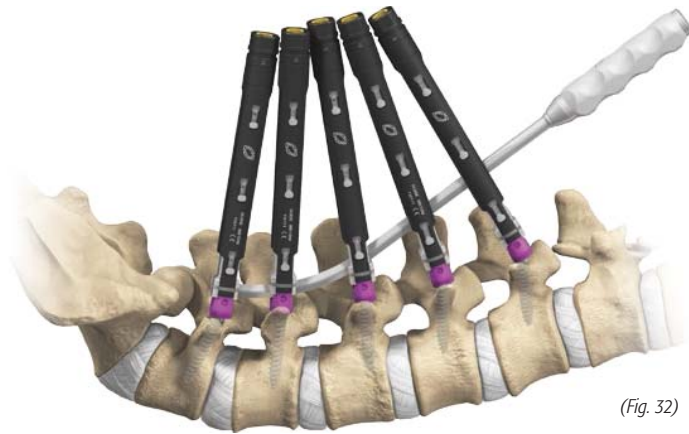

(Fig. 32)

#### OBTUSE ROD INSERTER

With the rod engagement dimple facing up, place the faceted end of the rod into the distal tip of the Obtuse Rod Inserter (Fig. 33). Engage the Inserter Driver into the hexalobe on the proximal end of the inserter. Turn the Inserter Driver clockwise to engage and lock the rod to the Obtuse Rod Inserter (Fig. 34). To remove the rod, engage the Inserter Driver into the hexalobe on the proximal end of the inserter and turn counterclockwise.

#### ACUTE ROD INSERTER

Turn the thumb wheel counterclockwise on the proximal end of the Acute Rod Inserter handle. With the rod engagement dimple facing up, place the faceted end of the rod into the distal tip of the Acute Rod Inserter. Turn the thumb wheel clockwise to engage and lock the rod to the inserter (Fig. 35). To remove the rod, turn the thumb wheel counterclockwise.

#### ADJUSTABLE ROD INSERTER

In the 90° position, turn the knurled knob on the proximal end of the Adjustable Rod Inserter counterclockwise. With the rod engagement dimple facing up, place the faceted end of the rod into the distal tip of the inserter. Turn the knurled knob clockwise to lock the faceted end of the rod to the inserter **A**. To adjust the angle of the rod, pull UP (axially) on the knurled knob (Fig. 36) **B**. To remove the rod, the Adjustable Rod Inserter must be in the 90° position. Turn the knurled knob counterclockwise to release.

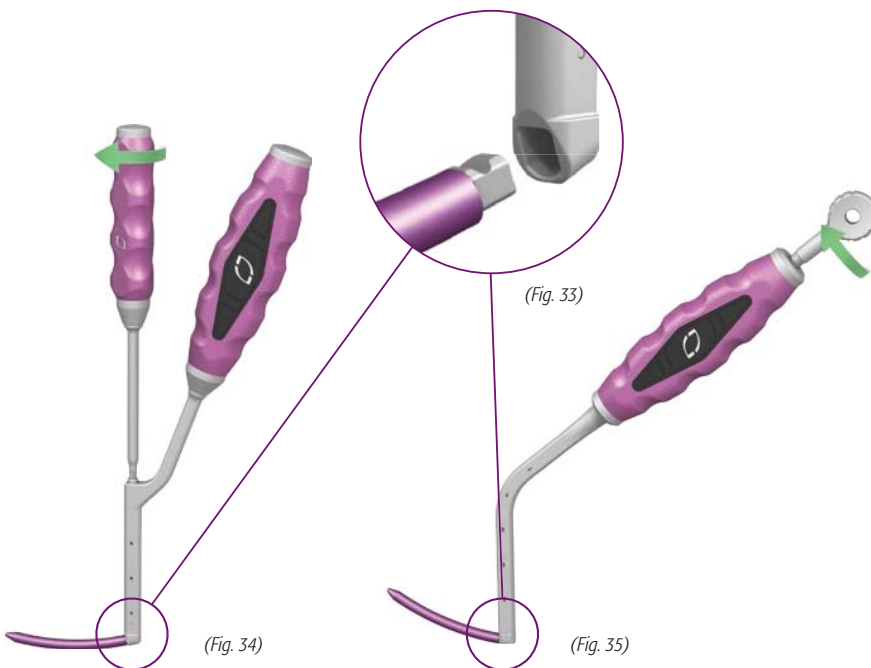

(Fig. 33)



(Fig. 34)

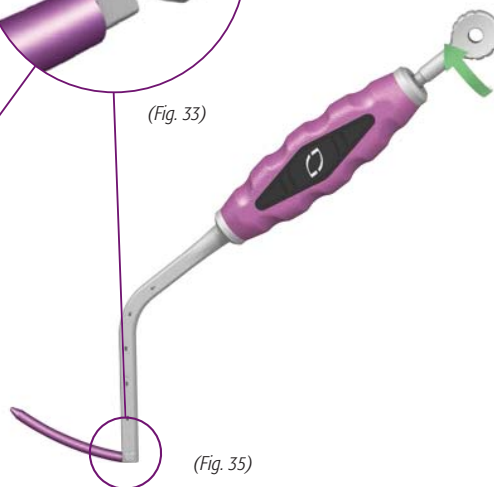

(Fig. 35)

#### NOTE

To remove the rod, the Adjustable Rod Inserter must be in the 90° position.



(Fig. 36)

PRECEPT™ CORE TECHNIQUE

**STEP 11:  
ROD INSERTION (CONT.)**

Prior to rod insertion, it is important to align the Guides so that there is a smooth lordotic curvature between the tops of the Guides. In addition, align the rod slot of the Guides along the rod pathway and connect the skin incisions. Insert the rod along the skin into the superior Guide with a trajectory toward the adjacent, inferior screw. This technique can be used with the Adjustable (*Fig. 36*), Acute (*Fig. 35*), or Obtuse Rod Inserter (*Fig. 34*).

Advance the rod through the Guides while pushing the handle of the Rod Inserter toward the skin, as necessary, to fully insert the rod. It may be necessary to make fine adjustments to the angle and rotation of the Guides and Rod Inserter during rod passage to accommodate variances in medial/lateral screw alignment (*Fig. 37*).

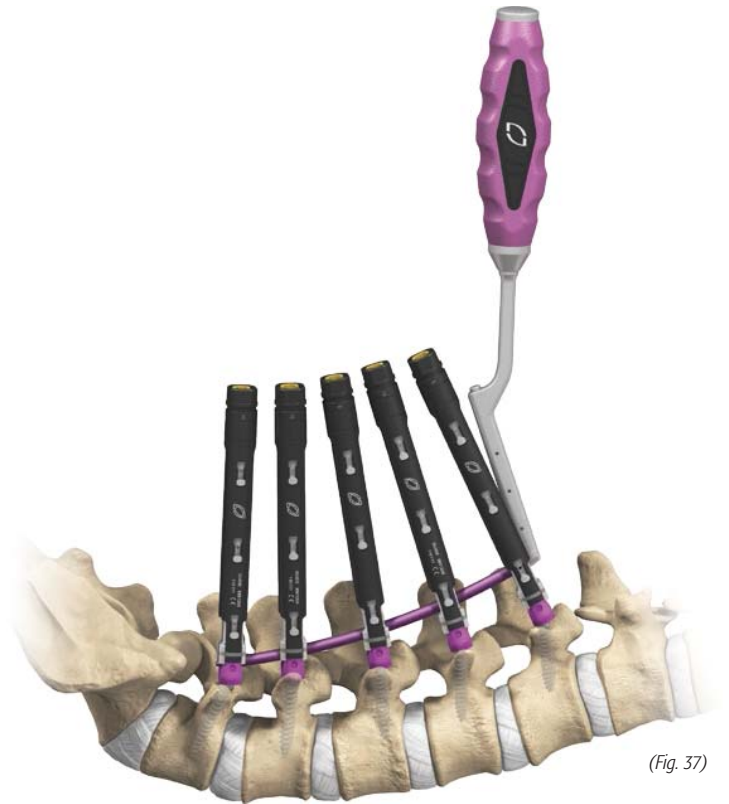

(Fig. 37)

## PRECEPT™ CORE TECHNIQUE

### STEP 12: LOCK SCREW INSERTION

**NOTE**

All lock screws must be loaded silver side up.

#### Standard Lock Screw Starter

Ensure the gold knob is turned counterclockwise one full turn. With the lock screw in the caddy, engage the Lock Screw Starter into the lock screw (Fig. 38). Rotate the proximal gold knob clockwise to expand the hexalobe tip and retain the lock screw (Fig. 39). Deliver the lock screw through the Guide (Fig. 42) until the green line on the shaft of the Lock Screw Starter is recessed below the proximal end of the Guide (Fig. 40a). To release the lock screw, turn the gold knob counterclockwise and remove the Starter from the lock screw by pulling UP (axially).



(Fig. 38)

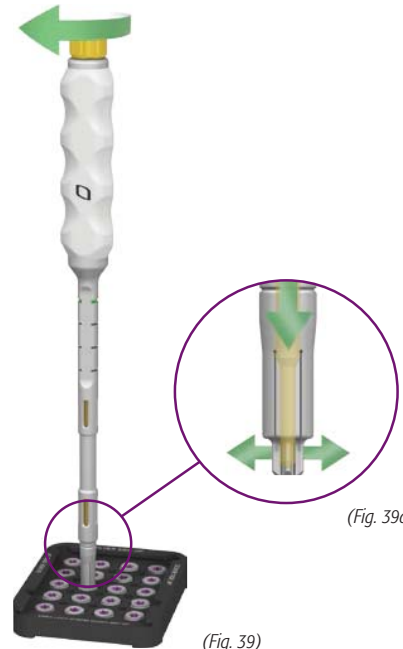

(Fig. 39a)

(Fig. 39)

**OPTIONAL**

#### Multi-Load Lock Screw Starter

The Multi-Load Lock Screw Starter can hold up to six lock screws (Fig. 40). Load directly from the caddy, pushing the tip of the Starter through the lock screw (Fig. 41). It is important to turn the instrument while applying downward pressure to align drive features on the lock screw and Lock Screw Starter.

**Tips and Tricks**

Releasing the lock screw from the instrument is easier after tightening the lock screw into the tulip.

**MULTI-LOAD**

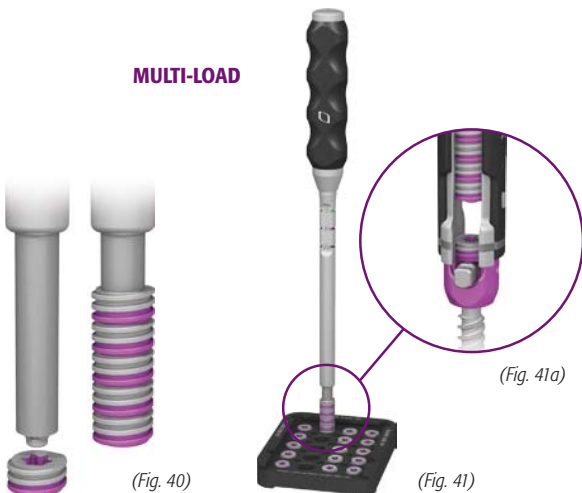

(Fig. 40)

(Fig. 41a)

(Fig. 41)

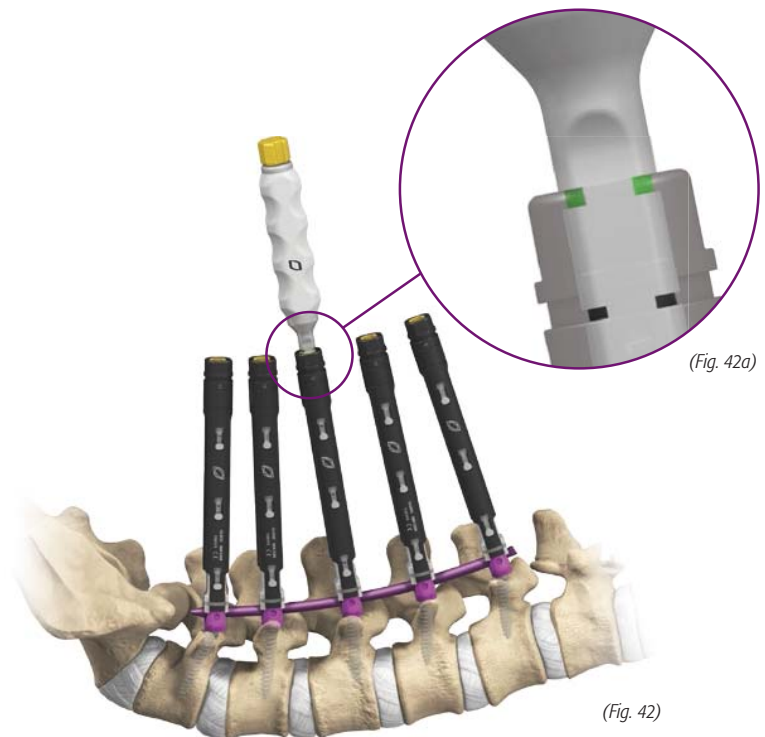

(Fig. 42a)

(Fig. 42)

PRECEPT™ CORE TECHNIQUE

**STEP 13:**  
**REDUCTION (OPTIONAL)**

**Bulldozer (Primary Option)**

The Bulldozer is the primary reduction option that allows up to 30mm of reduction. Use the Bulldozer at highly lordotic angles or any segment where the rod normalizing to the tulip will be challenging.

With the lock screw in the caddy, load the lock screw onto the distal tip of the Bulldozer. Insert the Bulldozer over the Guide while lining up the laser marks on both the Guide and Bulldozer. Push the Bulldozer down (axially) until the gold tabs positively engage with the top of the Guide.

Place the Reduction Attachment onto the reduction knob and turn clockwise until the rod is fully reduced into the tulip (Fig. 44).

The rod is fully reduced when the measurement window indicates "0" (Fig. 45).

Remove the Reduction Attachment and place the Lock Screw Attachment on the lock screw knob. Turn counterclockwise to align the interlocking flanges. Once the interlocking flanges are aligned, turn clockwise until the lock screw is delivered.

Remove the Bulldozer by turning the reduction knob counterclockwise several turns, and pulling up (axially) on the lock screw knob to disengage the Bulldozer from the lock screw. Depress the gold tabs and remove the Bulldozer.

**NOTE**

The illustration shows two positions: "FULLY REDUCED" and "NOT REDUCED" (Fig. 43).

**Tips and Tricks**

Set reduction on the Bulldozer to the desired level prior to surgeon use.

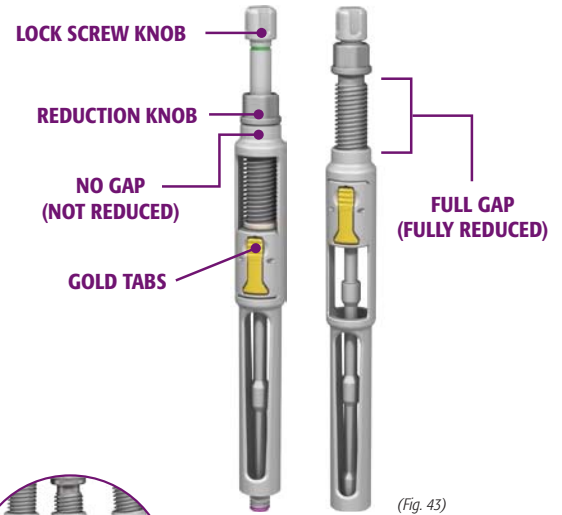

(Fig. 43)

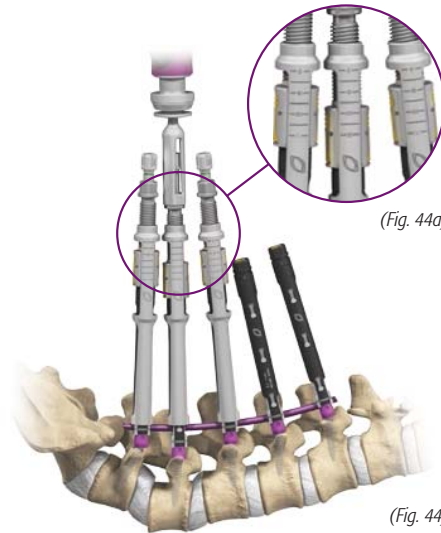

(Fig. 44a)

(Fig. 44)

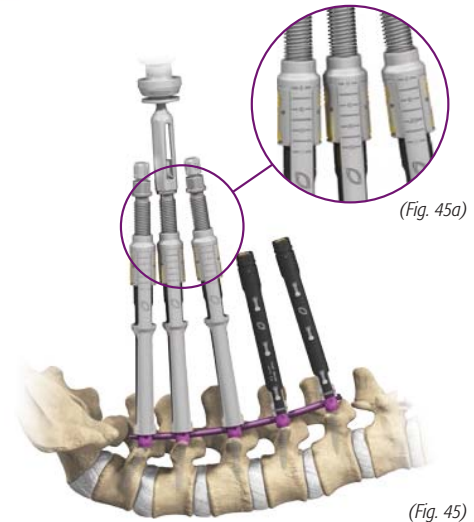

(Fig. 45a)

(Fig. 45)

## PRECEPT™ CORE TECHNIQUE

### STEP 13: REDUCTION (OPTIONAL) (CONT.)

#### Reduction Lock Screw Starter "Pile Driver" (Alternative Option)

The "Pile Driver" is an alternative reduction option that allows up to 50mm of gradual, controlled reduction through the Guide.

With the lock screw still in the caddy, load the lock screw onto the distal tip of the "Pile Driver," ensuring the hexalobe feature protrudes through the lock screw (Fig. 46).

Insert the "Pile Driver" through the top of the Guide, and ensure the gold locking tabs positively engage (snap into) the Guide. Pull UP (axially) on the purple handle to verify full engagement. Rotate the handle clockwise until the rod is fully reduced (Fig. 47). When the green line is completely buried (Fig. 48) below the silver reduction knob (indicating full reduction), turn the silver lock screw knob counterclockwise until an audible "click" is heard. The "click" confirms the interlocking flanges of the tulip are aligned with the interlocking flanges of the lock screw. Turn the silver lock screw knob clockwise to deliver the lock screw. The lock screw knob will no longer turn when the lock screw is fully delivered. To remove the "Pile Driver," back off reduction by turning the purple handle counterclockwise 10mm. Then press the top of the gold tabs, and remove the "Pile Driver."

#### NOTE

The Reduction T-handle and attachment may be used for added torque during reduction.

#### CAUTION

Ensure the Guide is perpendicular to the rod when reducing with the "Pile Driver."

#### Tips and Tricks

For easier loading, slightly turn the silver lock screw knob while applying downward pressure to aid in mating the hexalobe features.

#### Tips and Tricks

Reduce the middle levels and superior/inferior levels of a construct simultaneously for easier rod seating. Ensure each Guide is perpendicular to the rod when reducing with the "Pile Driver" to confirm the rod is normalized.

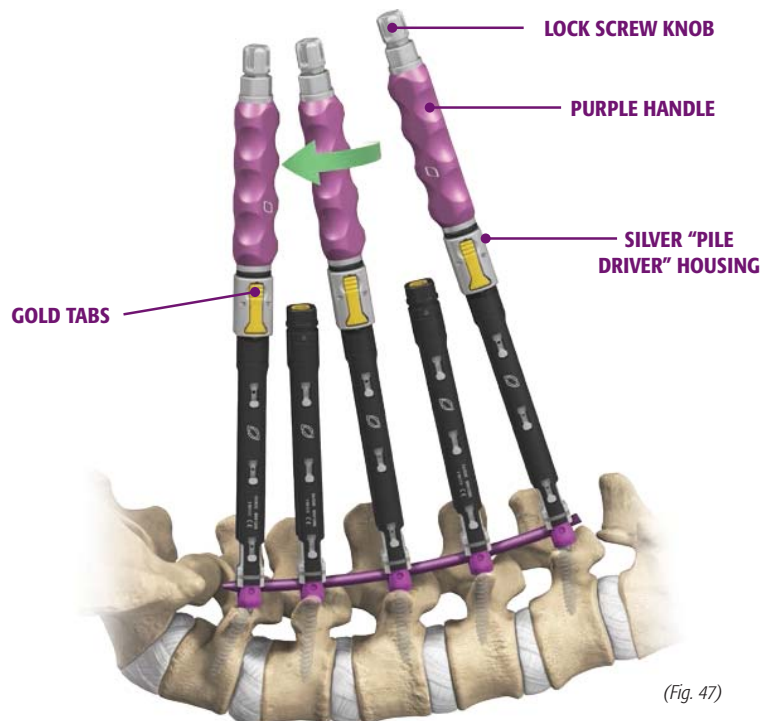
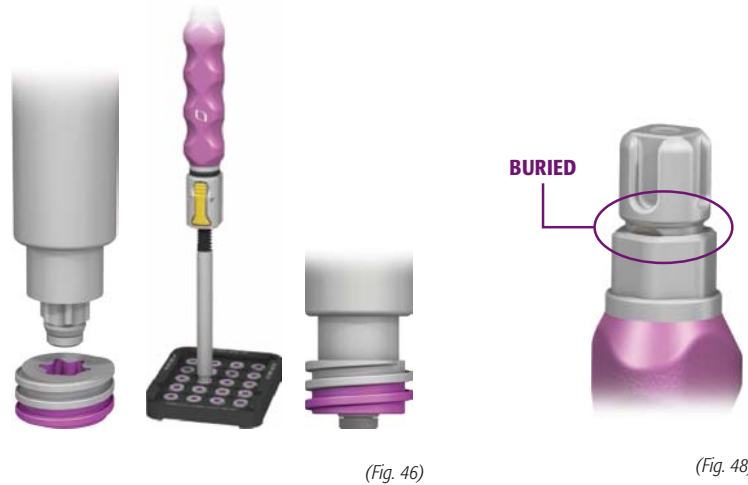

PRECEPT™ CORE TECHNIQUE

**STEP 13:**  
**REDUCTION (OPTIONAL) (CONT.)**  
**“Pistol” Grip (Alternative Option)**

The “Pistol” Grip is an alternative reduction option that allows for 15mm of reduction. Load the lock screw onto the “Pistol” Grip Reducer with the lock screw still in the caddy. Ensure that the tip of the instrument passes entirely through the lock screw. With the lock screw engaged, insert the Reduction Driver through the top of the Guide and ensure that the gold locking tabs positively engage (snap into) the Guide by pulling up on the handle. Squeeze the handle for desired reduction until the green line is buried and the rod is fully seated (Fig. 49a). Turn the silver lock screw knob counterclockwise to align on the interlocking flanges. Turn the handle on the center shaft clockwise to drive the lock screw into the tulip. The lock screw will no longer turn when the lock screw is fully delivered (Fig. 49).

To remove, back off reduction by squeezing the handle and pulling the rack lever. Push the gold tabs and pull UP (axially).

**Tips and Tricks**

*If it becomes difficult to engage the reduction instruments, ensure gold castle nut on Guide is fully seated.*

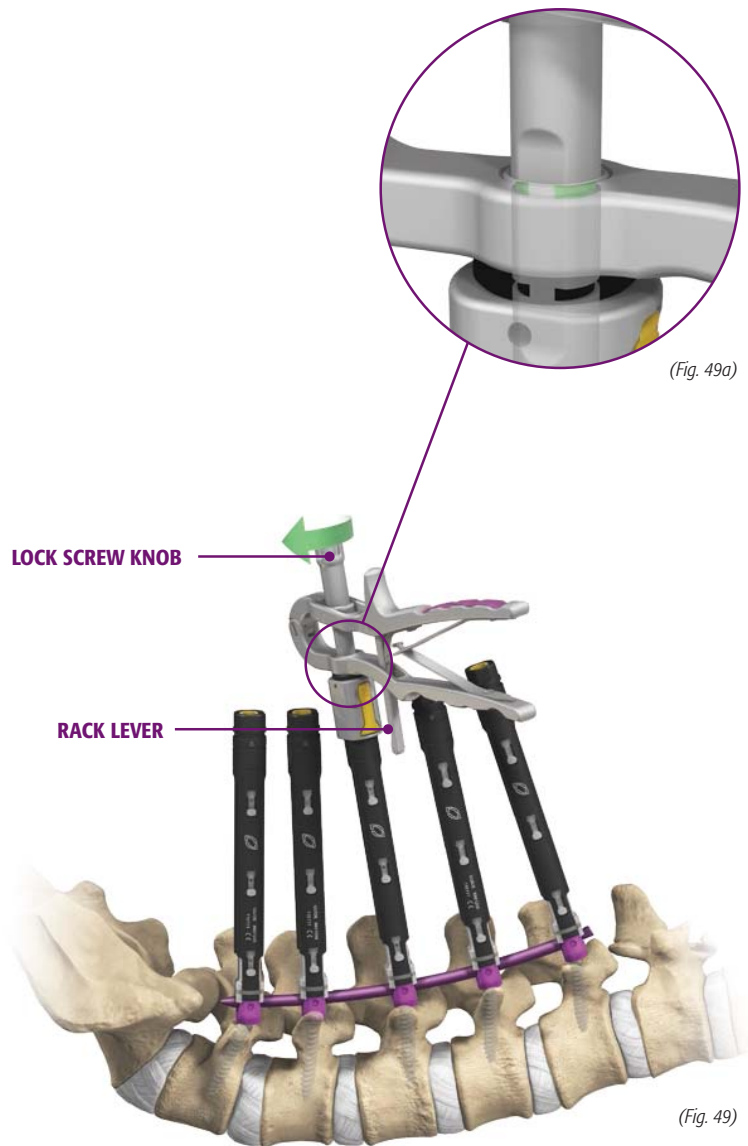

(Fig. 49a)

(Fig. 49)



## PRECEPT™ CORE TECHNIQUE

### STEP 13: REDUCTION (OPTIONAL) (CONT.)

#### Single-Level Reducer (Alternative Option)

When reduction is needed over a single-level construct, the Single-Level Reducer can be used bilaterally.

Single-Level Reducer steps (use bilaterally):

1. WITHOUT the Single-Level Reducers attached to the Guides, final-tighten the level used as the fulcrum point (i.e., the level not being reduced) (Fig. 51).
2. Attach the Single-Level Reducer to the Guides and reduce (Fig. 52).
3. Insert a lock screw with the standard Lock Screw Starter and provisionally tighten to hold the reduction (Fig. 53).
4. Remove the Single-Level Reducer from the Guides.
5. Final-tighten the provisionally tightened lock screw (Fig. 54).

#### CAUTION

**Do not final-tighten through the Single-Level Reducer, as the rod may not have the freedom to normalize to the tulip (Fig. 54).**



(Fig. 50)

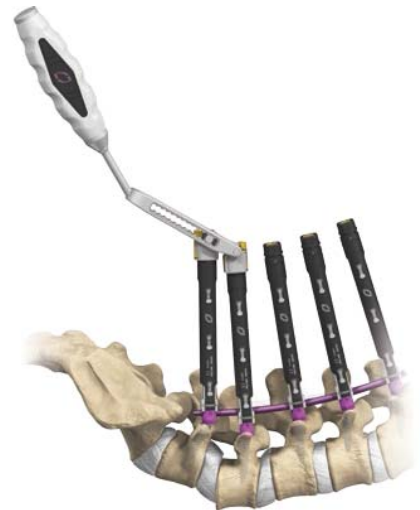

(Fig. 51)

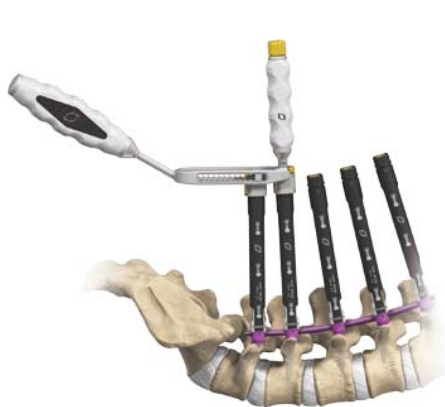

(Fig. 52)



(Fig. 53)



(Fig. 54)

PRECEPT™ CORE TECHNIQUE

**STEP 14:**  
**COMPRESSION/DISTRACTION (OPTIONAL)**

Fulcrum "Pistol" Grip compressor steps:

1. WITHOUT the fulcrum compressor attached to the Guides, final-tighten one lock screw with the Torque T-handle and Counter-Torque (Fig. 56).
2. Engage (but leave loose) a lock screw in the other Guide, spanning the level(s) to be compressed (Fig. 56).
3. Insert the fulcrum compressor rack into the main body of the fulcrum compressor by pressing the compressor handle's silver button.
4. Insert the body of the fulcrum compressor into the Guide that is final-tightened.
5. Attach a ratcheting handle (not the Torque T-handle) to the compressor final driver.
6. Insert the compressor final driver through the fulcrum compressor rack and corresponding Guide. While inserting the driver into the compressor and Guide, press the button, allowing the rack to move freely until the Guide and rack are aligned. The alignment, in turn, allows the driver to freely seat into the Guide and engage the lock screw.
7. Squeeze the handles to drive compression.
8. Provisionally tighten the lock screw to hold the compression. Remove the entire fulcrum compressor assembly (Fig. 57).
9. Final-tighten the provisionally tightened lock screw, using the Torque T-handle and Counter-Torque (Fig. 58).

**CAUTION**

**Do not final-tighten through the fulcrum compressor, as the rod may not have the freedom to normalize to the tulip (Fig. 59).**

**Tips and Tricks**

*To remove the compressor, disengage the rack and release the compression lead of the instrument. In addition, squeeze and separate (unsqueeze) the handle to aid in removal.*



(Fig. 55)

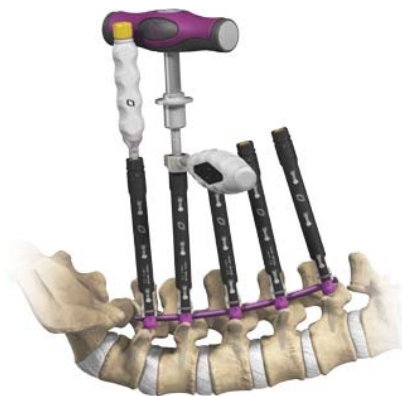

(Fig. 56)



(Fig. 57)

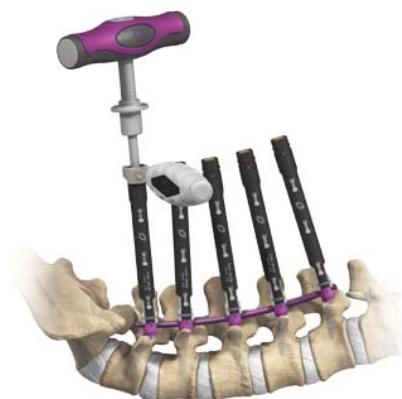

(Fig. 58)

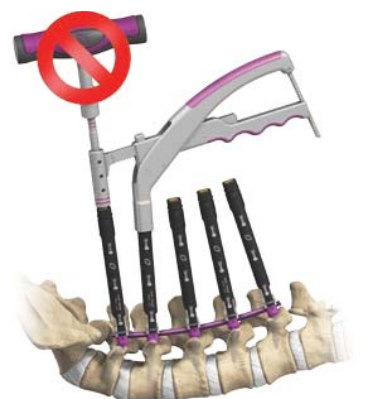

(Fig. 59)

## PRECEPT™ CORE TECHNIQUE

### STEP 14: COMPRESSION/DISTRACTION (OPTIONAL) (CONT.)

#### Rack Compressor Distractor steps:

1. WITHOUT the Rack Compressor Distractor attached to the Guides, final-tighten one lock screw with the Torque T-handle and Counter-Torque (Fig. 60).
2. Engage (but leave loose) a lock screw in the other Guide(s). The screw should span the level(s) to be compressed (Fig. 60).
3. Attach the rack to the arms and assemble (Fig. 61).  
To assemble:
  - a. Slide the arms over the Guides until they are seated on top of the rod.
  - b. With the rack in the neutral position, align the rack to the arms.
  - c. Simultaneously press the arms into the rack until there is full engagement.
4. Compress (or distract) as needed by toggling the lever from the neutral position to either the "C" (compression) or "D" (distraction) position, and then rotating the gold knob.
5. Hold compression and provisionally tighten the lock screw, using a ratcheting handle and final driver (Fig. 62).
6. Remove the entire Rack Compressor Distractor assembly.
7. Final-tighten the provisionally tightened lock screw, using the Torque T-handle and Counter-Torque (Fig. 63).



(Fig. 60)

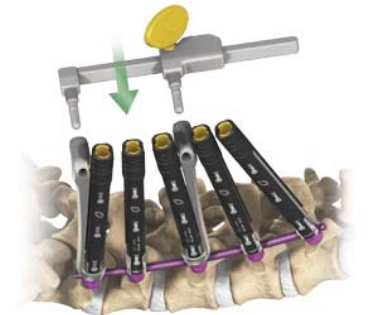

(Fig. 61)

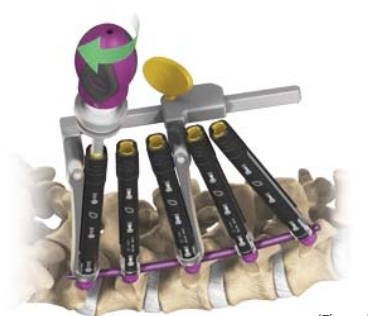

(Fig. 62)

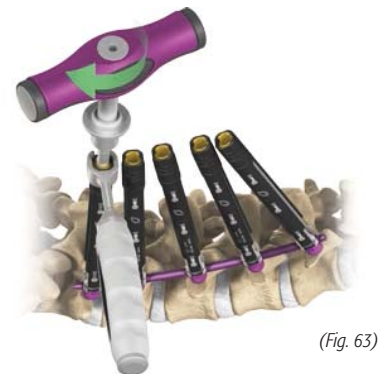

(Fig. 63)

#### CAUTION

**Do not final-tighten through the Rack Compressor Distractor, as the rod may not have the freedom to normalize to the tulip (Fig. 64).**

#### Tips and Tricks

For easier loading of the arms to the rack, leave the arms loose (i.e., don't engage the splines on the male portion of the rack). Once the rack is in the correct position, simultaneously attach both arms.

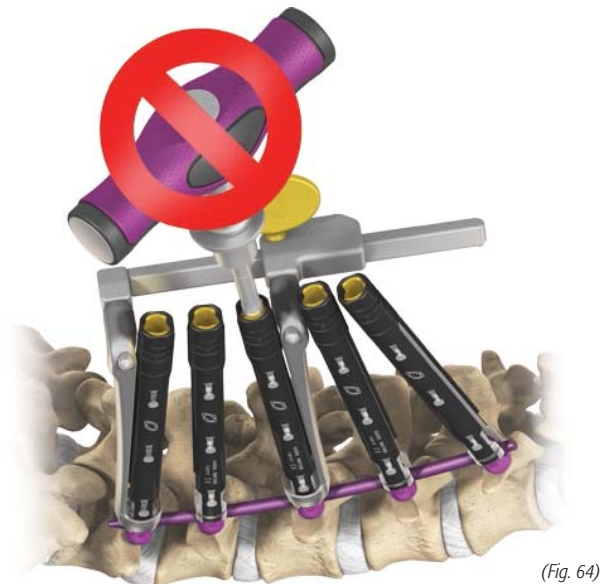

(Fig. 64)

## PRECEPT™ CORE TECHNIQUE

### STEP 15: FINAL TIGHTENING

Align the flats on the Counter-Torque with the flats on the top of the Guide. Fully seat the Counter-Torque onto the top of the Guide. Insert the Lock Screw Driver with the Torque T-handle attached (Fig. 65). Final-tighten and remove the driver, Torque T-handle, and Counter-Torque.

#### CAUTION

All lock screws should be final-tightened with the Counter-Torque and Torque T-handle. Do not final-tighten through other instruments in the set, as the rod may not be able to normalize to the tulip.

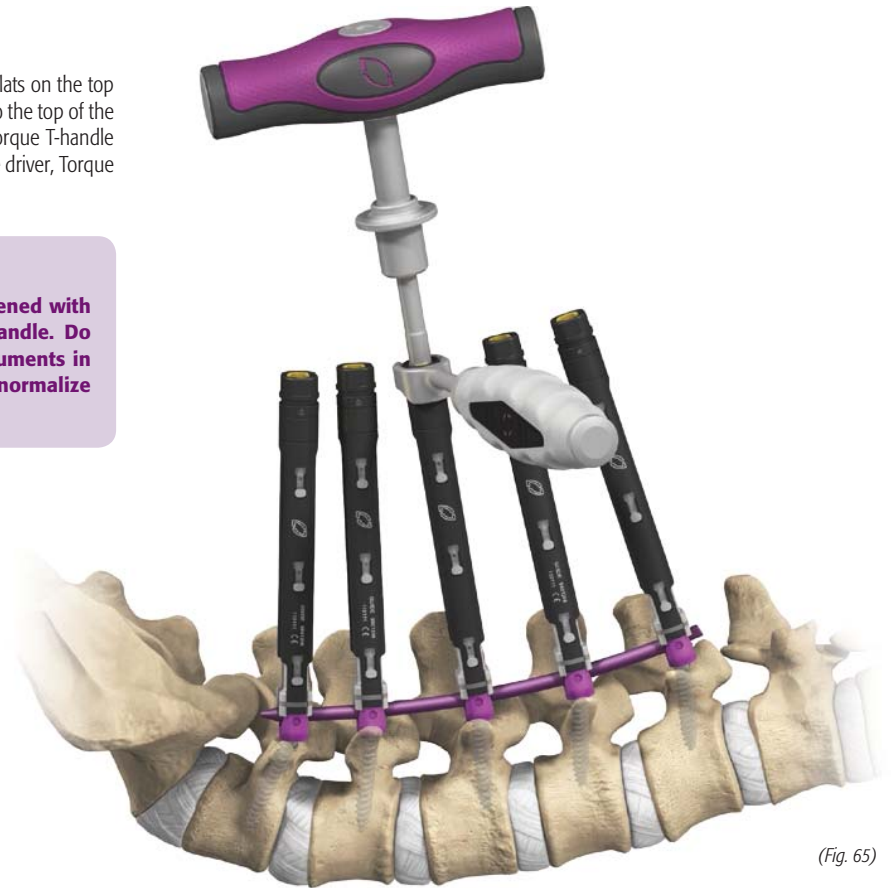

(Fig. 65)

## PRECEPT™ CORE TECHNIQUE

**STEP 16:  
GUIDE REMOVAL**

Insert the Guide Locking Cap into the proximal end of the Guide. Turn the Guide Locking Cap counterclockwise until the gold castle nut is completely backed out (Fig. 66). Rotate the Guide 90° to release the engagement features from the screw head. Then pull UP (axially) to remove the Guide.

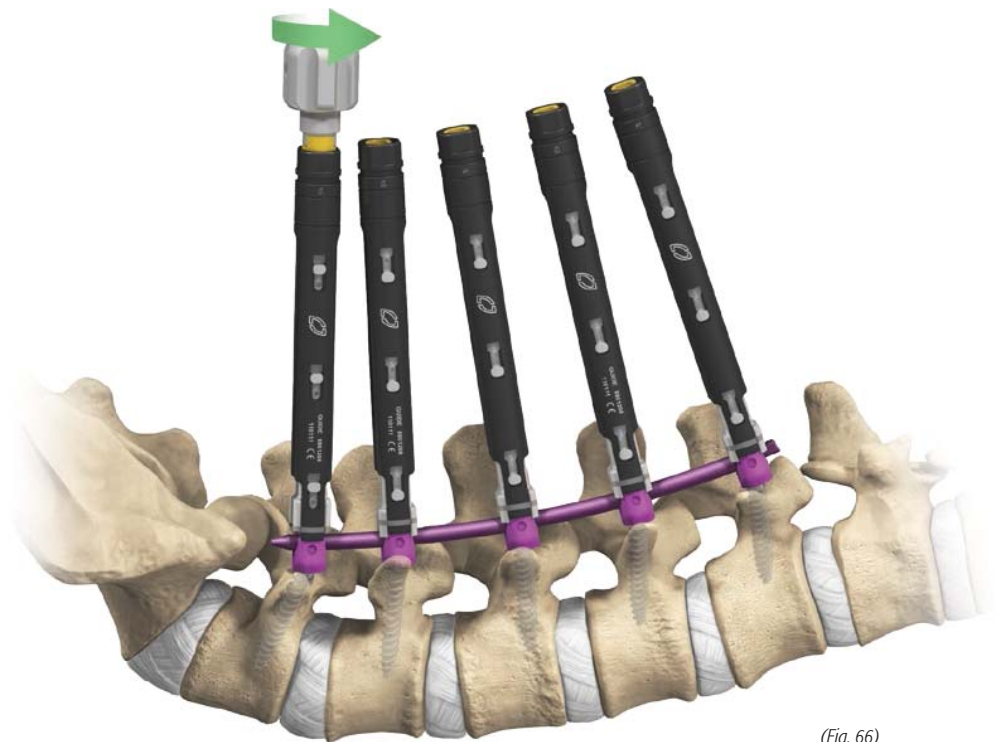

(Fig. 66)

PRECEPT™ CORE TECHNIQUE

**STEP 17:**  
**SLIP-ON GUIDE REMOVAL**

If the Slip-on Guide was used, it can be removed with the Slip-on Guide Removal Tool. Align the black laser marks to the Guide, and slide the Slip-on Guide Removal Tool body into the Guide while the gold stylet is out of the Slip-on Guide Removal Tool body (Fig. 67). Once the Slip-on Guide Removal Tool body is fully seated, plunge the gold stylet down into the Guide (Fig. 68), and remove all components by pulling up on the Guide (Fig. 69).

To release the Slip-on Guide Removal Tool from the Slip-on Guide, first pull out the center gold shaft completely, and then pull the removal tool body out of the Slip-on Guide.

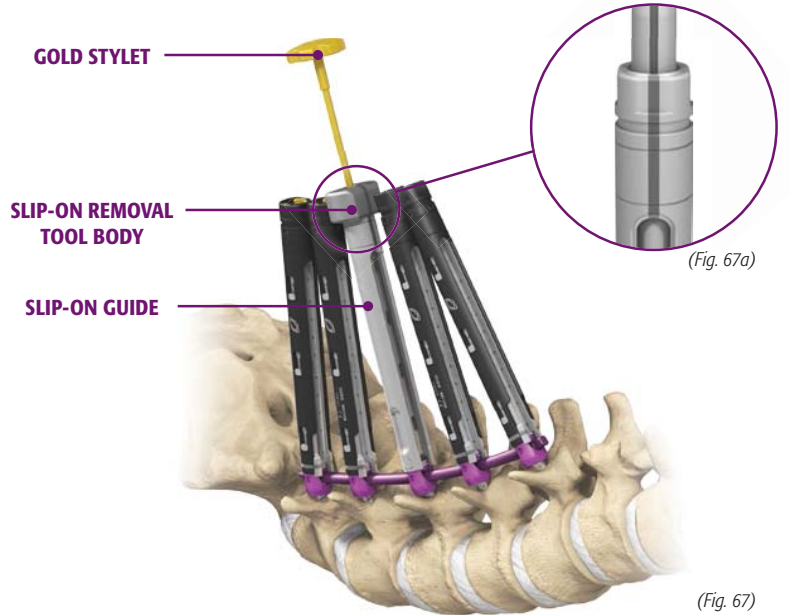

(Fig. 67a)

(Fig. 67)

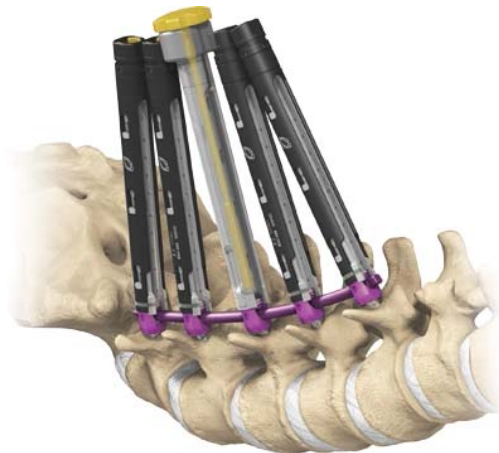

(Fig. 68)

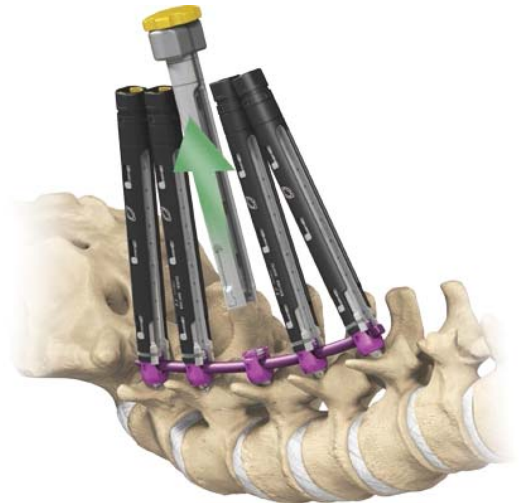

(Fig. 69)

**PRECEPT™ CORE TECHNIQUE****IMPLANT REMOVAL****Step 1: Lockscrew Removal**

Insert the Lockscrew Driver into the Lockscrew. Slide the Counter-Torque tube over the Lockscrew Driver and seat around the tulip with the rod slots over the rod. Engage the T-handle to the Lockscrew Driver and turn counterclockwise until the Lockscrew is loosened but not disengaged from the tulip threads. Repeat on all of the screws until all Lockscrews have been loosened. Remove the Lockscrew Driver and engage the Lockscrew Starter in the Lockscrew. Turn counterclockwise until the Lockscrew threads are fully disengaged from the tulip and pull the Lockscrew and Lockscrew Starter out through the Counter-Torque. Repeat the process until all Lockscrews have been removed.

**Step 2: Rod Removal**

Once all of the Lockscrews and cross connectors have been removed, slide the rod retrieval tool over the most cephalad or caudal portion of the rod. Tighten the tool onto the rod and pull the rod through the screw incision.

**Step 3: Screw Removal**

Insert the tip of either the Screw Adjuster or the Screwdriver into the screw shank. Rotate the Screwdriver or Screw Adjuster counterclockwise until it is fully out of the bone.

PRECEPT™ CORE TECHNIQUE GUIDE

**NVM5: SEAMLESS PROCEDURAL INTEGRATION**

The challenge to any minimally disruptive pedicle screw procedure lies in the inherent lack of direct visualization of the pedicle. Moreover, screw placement is traditionally limited to 2D confirmation with fluoroscopic imaging. Using a proprietary, threshold-determining hunting algorithm, NVM5 provides real-time feedback of initial pilot hole formation and throughout pedicle screw placement.

**DYNAMIC SCREW TEST**

Real-time, continuous feedback is displayed as easy-to-interpret, color-coded, numeric threshold responses. The Screw Test functions allow the surgeon to locate and evaluate spinal nerves by providing proximity information before, during, or after bone preparation and placement of bone screws. Continuous stimulated EMG is seamlessly applied to Precept™ instruments to provide real-time information during:

- Pedicle Targeting Using I-PAS™ III
- Tapping
- Screw Insertion



**FREE RUN EMG**

The Free Run EMG function identifies spontaneous EMG activity of spinal nerves by continually displaying a live stream waveform of any mechanically induced myotome contractions. This is particularly valuable during:

- Rod Insertion
- Distraction
- Compression
- Final Tightening











# PRECEPT™ REDUCTION SCREW TECHNIQUE

## PRECEPT™ REDUCTION SCREW TECHNIQUE

Follow the instructions on pages 4-7 of the Core Technique before beginning with the following steps.

### STEP 1: SCREW INSERTION

#### Loading:

1. After K-Wires are in place, insert the Screwdriver through the Reduction Screw, until the Screwdriver tip engages the screw shank and the shaft becomes rigid (*Fig. 1*).
  - While holding the screw in one hand, firmly tighten the driver by turning the trilobe clockwise.

#### NOTE

**It is important to align the distal wings on the driver with the rod slot, ensuring the driver will pass through the threads.**

#### Insertion:

2. Ensuring axial alignment, drive the screw shank into bone.
  - Do not bury the tulip head into bone (i.e., keep polyaxial motion of the tulip).
3. To remove the Screwdriver, turn the trilobe counterclockwise.
4. Repeat the above process as each Reduction Screw is inserted.

### STEP 2: ROD MEASUREMENT

Insert the arms of the Rod Measurement Tool into the proximal ends of the superior and inferior screws, and advance the arms down into the screw heads (*Fig. 2*). Full seating of the Rod Measurement Tool is confirmed when the grooves at the top of the arms are positioned at the top of both screws. It may be necessary to angle the Rod Measurement Tool cephalad and caudal to fully seat the distal end of the measurement tool into the screw heads. It is important to note the displayed measurement will indicate the distance between the screw shanks. The surgeon will add length as necessary.

#### NOTE

**It may be necessary for the surgeon to add length to the rod, depending upon patient anatomy and desired lordosis. As a general rule, add 15mm. If the measurement is in-between rod sizes, always round up to the next rod length. For long constructs, it may be necessary to add more length.**



(Fig. 1)

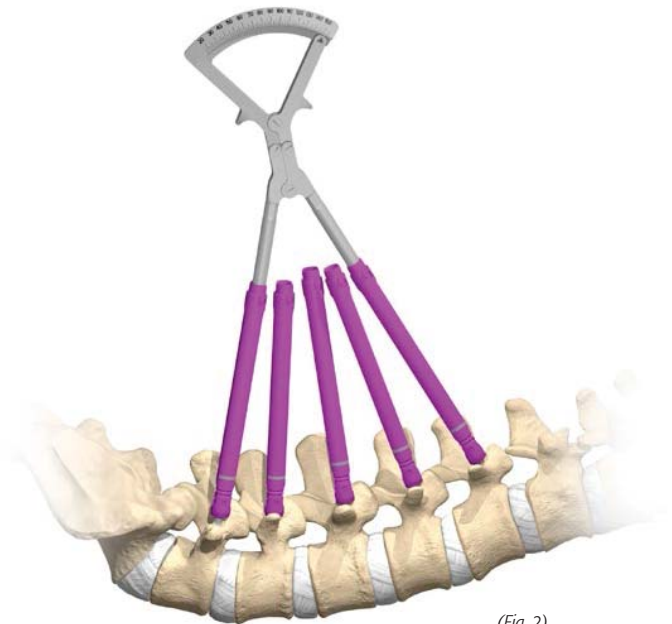

(Fig. 2)

## PRECEPT™ REDUCTION SCREW TECHNIQUE

### STEP 3: ROD INSERTION

Prior to rod insertion, align the rod slot of the screws along the rod pathway (Fig. 3). Rod passage is demonstrated in the Core Technique on pages 17 and 18.

### STEP 4: LOCK SCREW INSERTION

#### Standard Lock Screw Starter

With the lock screw in the caddy, engage the Lock Screw Starter into the lock screw. Rotate the proximal gold knob clockwise to expand the hexalobe tip and retain the lock screw. Deliver the lock screws through the screw until the green line on the shaft of the Lock Screw Starter is recessed below the proximal end of the Reduction Screw (Fig. 4). To release the lock screw, turn the gold knob counterclockwise and remove the Starter from the lock screw by pulling UP (axially).

#### NOTE

If the reduction extensions were split at the top, then it is necessary to place the Reduction Attachment (Top Hat) on the tabs prior to starting the lock screw.

#### NOTE

Do not use the Multi-Load Lock Screw Starter with the Reduction Screws, as the caps will prematurely engage.

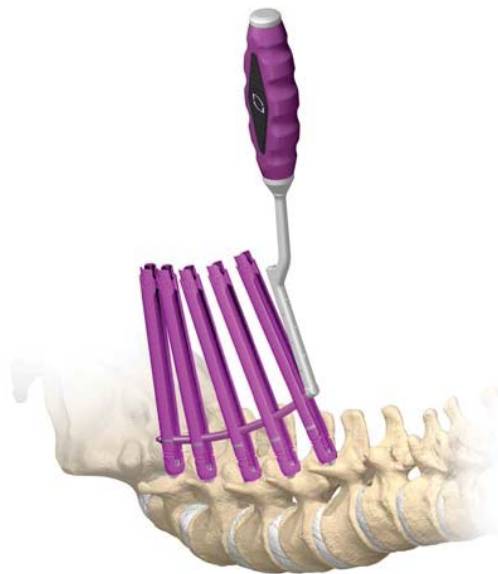

(Fig. 3)

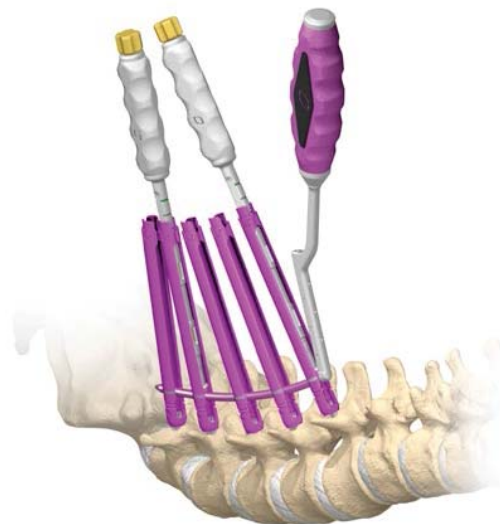

(Fig. 4)

## PRECEPT™ REDUCTION SCREW TECHNIQUE

### STEP 5: REDUCTION ATTACHMENT (TOP HAT)

The Top Hat is required when other Core system instruments are used in conjunction with the Reduction Screws. To assemble, align the laser lines on the Top Hat with the open groove at the top of the screw, and turn counterclockwise to secure (Fig. 5).



### STEP 6: “PILE DRIVER”/“PISTOL” GRIP REDUCTION (OPTIONAL)

If additional reduction beyond the 12.5mm of built-in reduction is necessary, the “Pile Driver” or the “Pistol” Grip Reducer can be used in conjunction with the Top Hat (Fig. 6). Please refer to the Core Technique on pages 21 and 22 for proper technique.



(Fig. 5)

#### NOTE

Via the Reduction T-handle, the “Pile Driver”/ “Pistol” Grip Reducer will deliver the lock screw only until it reaches the reduction threads. The Lock Screw Starter on the “Pile Driver”/“Pistol” Grip Reducer will then be turned until the lock screw is delivered slightly farther in the reduction threads. It is necessary to use the standard Lock Screw Driver to fully deliver the lock screw.

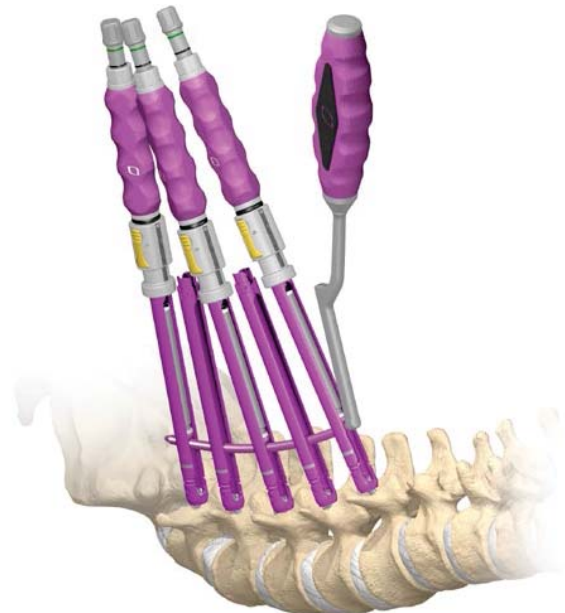

(Fig. 6)

## PRECEPT™ REDUCTION SCREW TECHNIQUE

**STEP 7:  
COMPRESSION (INLINE COMPRESSOR)**

Place the Reduction Screw Dilator over the Reduction Screw that is final-torqued. Then follow the same steps of compression as stated on page 24 and 25.

**STEP 8:  
FINAL TIGHTENING**

Place the Counter-Torque directly over the reduction tab (Fig. 7). Fully seat the Counter-Torque onto the top of the screw. Insert the Lock Screw Driver with the Torque T-handle attached. Final-tighten and remove the driver, Torque T-handle, and Counter-Torque.



(Fig. 7)

## PRECEPT™ REDUCTION SCREW TECHNIQUE

### STEP 9: REDUCTION SCREW SPLITTING

Place the Reduction Screw Splitting Tool directly on top of the superior reduction extension (Fig. 8). Turn the T-handle 360° until the reduction tab splits on both sides. An audible “click” will be heard at 180° and 360° during splitting (two “clicks”).

#### NOTE

**Downward (axial) force is not required when splitting the Reduction Screw tabs.**

### STEP 10: EXTENDED TAB BREAK-OFF

Slide the Break-off Tool over the lateral tab of the tulip with the convex side lateral to the patient (Fig. 9), and pull the Break-off Tool away from midline. On the contralateral tab, slide the Break-off Tool over the tulip with the convex side medial to the patient, and pull the Break-off Tool away from midline. To verify a clean break, check to ensure the black laser line is showing in the middle portion on the broken tab (Fig. 9). Use caution when palpating break point as the tulip may be sharp.

#### NOTE

**Be sure the lock screw is fully seated and the rod is fully reduced prior to breaking off the tabs.**

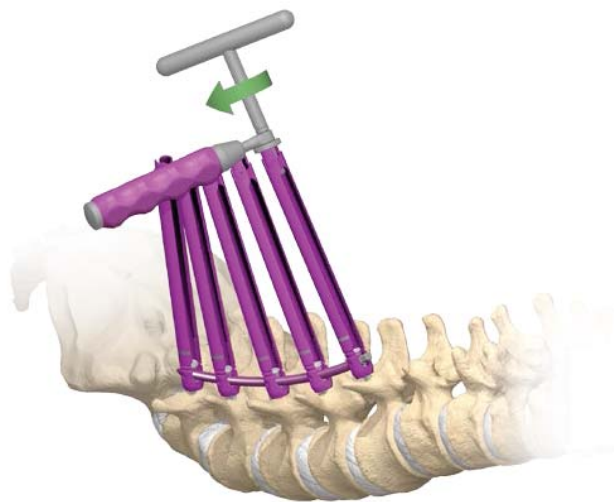

(Fig. 8)

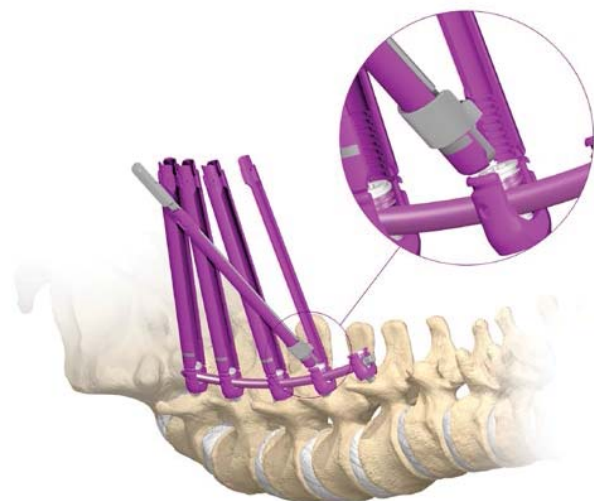

(Fig. 9)







# PRECEPT™ SYSTEM

PRECEPT™ SYSTEM

PRECEPT CORE INSTRUMENTS (TRAY ONE)

PRECEPT CORE INSTRUMENTS CASE



THREADED NITINOL K-WIRE



THREADED STAINLESS STEEL K-WIRE



BEVEL/BLUNT NITINOL K-WIRE



K-WIRE DRIVER



QUICK-CONNECT STRAIGHT HANDLE



RATCHETING TEARDROP HANDLE



PRIMARY DILATOR



## PRECEPT™ SYSTEM

### PRECEPT CORE INSTRUMENTS (TRAY ONE)

TAP DILATOR



SCREW DILATOR



FACET TUBE DILATOR



FACET TUBE



TAP-DILATOR COMBO



TAP 4.5mm



TAP 5.5mm



TAP 6.5mm



PRECEPT™ SYSTEM

PRECEPT CORE INSTRUMENTS (TRAY ONE)

TAP 7.5mm



STANDARD GUIDE

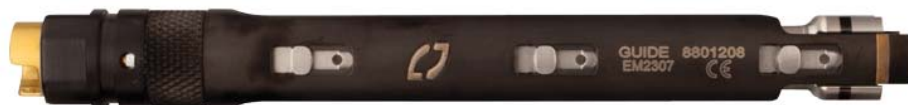

SLIP-ON GUIDE



SLIP-ON GUIDE REMOVAL TOOL



POLYAXIAL SCREWDRIVER



GUIDE LOCKING CAP



SCREW ADJUSTER



## PRECEPT™ SYSTEM

### PRECEPT CORE INSTRUMENTS (TRAY ONE)

GUIDE ADJUSTER



CURVED TISSUE DISSECTOR



ROD MEASUREMENT TOOL



ROD HOLDER



OBTUSE ROD INSERTER



INSERTER DRIVER



ADJUSTABLE ROD INSERTER



ACUTE ROD INSERTER



PRECEPT™ SYSTEM

PRECEPT CORE INSTRUMENTS (TRAY TWO)

PRECEPT CORE INSTRUMENTS CASE



THREADED ROD PUSHER



ROD PUSHER



LOCK SCREW ATTACHMENT



REDUCTION ATTACHMENT



STANDARD LOCK SCREW STARTER



MULTI-LOAD LOCK SCREW STARTER





## PRECEPT™ SYSTEM

### PRECEPT CORE INSTRUMENTS (TRAY TWO)

REDUCTION LOCK SCREW STARTER "PILE DRIVER"



BULLDOZER



"PISTOL" GRIP REDUCER

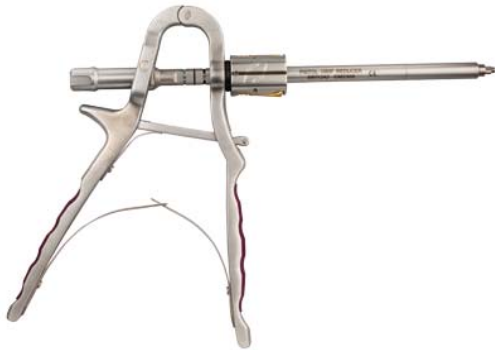

OPEN ROCKER



SINGLE-LEVEL REDUCER



TORQUE T-HANDLE



LOCK SCREW DRIVER



PRECEPT™ SYSTEM

PRECEPT CORE INSTRUMENTS (TRAY TWO)

REATTACHMENT TOOL



REDUCTION T-HANDLE



GUIDE COUNTER-TORQUE



FULCRUM "PISTOL" GRIP COMPRESSOR



FULCRUM COMPRESSOR RACK GUIDE



COMPRESSOR FINAL DRIVER



COMPRESSOR LEFT ARM, SHORT\*



COMPRESSOR RIGHT ARM, SHORT\*



\*Long arms (not pictured) are also available.

## PRECEPT™ SYSTEM

### PRECEPT CORE INSTRUMENTS (TRAY TWO)

RACK COMPRESSOR DISTRACTOR



FRENCH BENDER



### PRECEPT CORE LONG CONSTRUCT INSTRUMENTS

PRECEPT CORE LONG CONSTRUCT INSTRUMENTS CASE



### PRECEPT CORE IMPLANTS

PRECEPT CORE IMPLANTS CASE

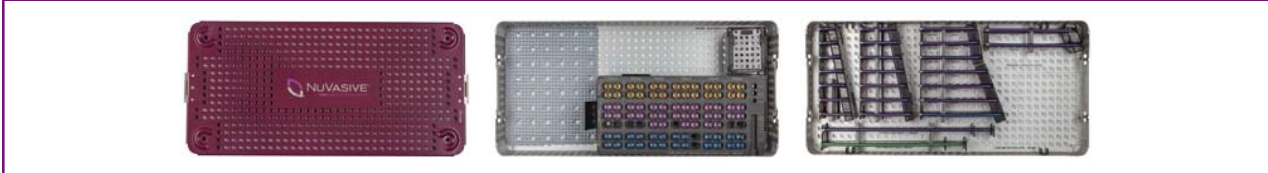

## PRECEPT™ SYSTEM

### PRECEPT REDUCTION IMPLANTS

#### PRECEPT REDUCTION IMPLANTS CASE

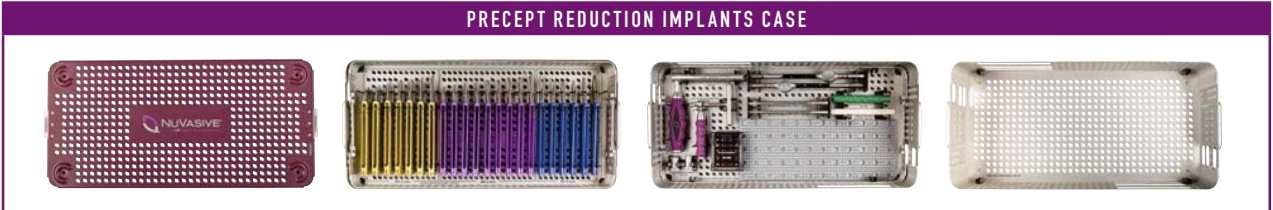

#### REDUCTION SCREW BREAK-OFF TOOL 1



#### REDUCTION SCREW BREAK-OFF TOOL 2



#### REDUCTION TAP DILATOR



#### REDUCTION SCREW DILATOR



## PRECEPT™ SYSTEM

### PRECEPT REDUCTION IMPLANTS (CONT.)

REDUCTION SCREWDRIVER



REDUCTION SPLITTING TOOL



REDUCTION SCREW COUNTER-TORQUE



REDUCTION ATTACHMENT (TOP HAT)



LOCK SCREW



REDUCTION SCREW



## PRECEPT™ SYSTEM

### PRECEPT MODULAR SYSTEM

#### PRECEPT MODULAR SYSTEM CASE

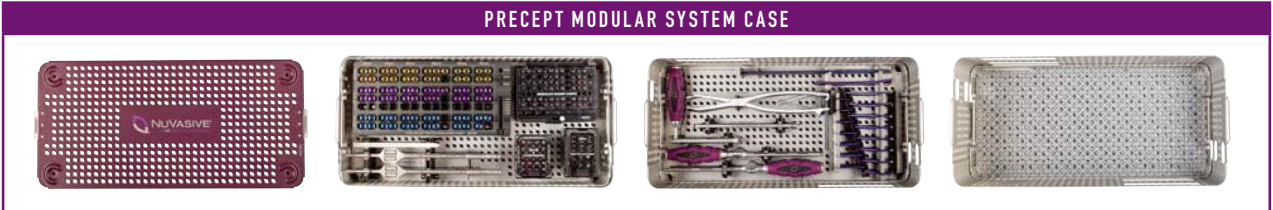

#### PRECEPT MODULAR SYSTEM CASE CADDIES



#### INSERTER MODULAR HEAD

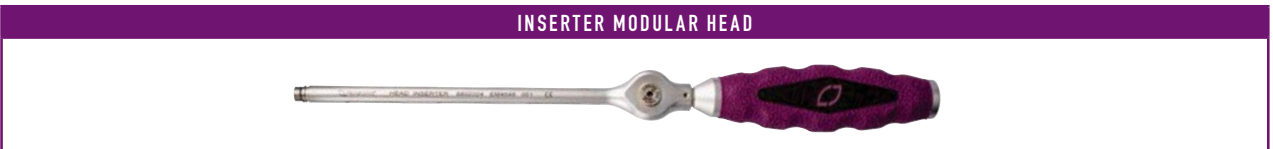

#### BLADE/DILATOR, MODULAR PRIMARY



#### LATERAL REAMER



## PRECEPT™ SYSTEM

### PRECEPT MODULAR SYSTEM (CONT.)

COMPRESSOR

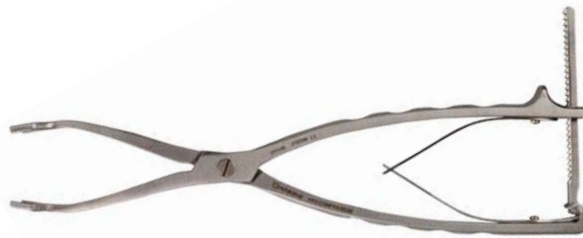

OPEN COUNTER-TORQUE



MODULAR TULIP



SHANK



POLYAXIAL SCREW



TI ROD, PRE-BENT LORDOTIC



TI ROD, STRAIGHT



**CATALOG**
**PRECEPT™ CORE INSTRUMENTS (TRAY ONE)**

DESCRIPTION	CATALOG #	QUANTITY
Threaded Stainless Steel K-Wire	8801000	14
Threaded Nitinol K-Wire	8801068	14
Bevel/Blunt Nitinol K-Wire	8801069	10
K-Wire Driver	8801002	1
Fascial Splitter Handle	8801070	1
Primary Dilator	8801203	1
Tap Insulator	8801204	1
Screw Insulator	8801205	1
Tap-Dilator Combo	8801211	2
Tap 4.5mm	8801345	1
Tap 5.5mm	8801355	1
Tap 6.5mm	8801365	1
Tap 7.5mm	8801375	1
Ratcheting Teardrop Handle	8801021	1
Quick-Connect Straight Handle, Short	8801020	2
Facet Tube Dilator	8801275	1
Facet Tube	8801277	1
Standard Guide	8801208	8
Slip-on Guide	8801210	1
Guide Adjuster	8801212	1
Guide Locking Cap	8801213	2
Polyaxial Screwdrivers	8801215	2
Screw Adjuster	8801222	1
Slip-on Guide Removal Tool	8801261	1
Rod Measurement Tool	8801223	1
Curved Tissue Dissector	8801224	1
Obtuse Rod Inserter	8801229	1
Acute Rod Inserter	8801232	1
Adjustable Rod Inserter	8801280	1
Inserter Driver	8801281	1
Rod Holder	8801034	1

**PRECEPT CORE INSTRUMENTS (TRAY TWO)**

DESCRIPTION	CATALOG #	QUANTITY
Threaded Rod Pusher	8801235	2
Rod Pusher	8801236	1
"Pile Driver"	8801238	2
Reduction Attachment	8801239	1
Lock Screw Attachment	8801240	1
"Pistol" Grip Reducer	8801242	1
Standard Lock Screw Starter	8801243	2
Multi-Load Lock Screw Starter	8801245	1
Open Rocker	8801064	1
Single-Level Reducer	8801066	2
Lock Screw Driver	8801244	1
Reattachment Tool	8801256	1
Torque T-handle	8801057	1
Bulldozer	8801074	2
Reduction T-handle	8801075	1
Guide Counter-Torque	8801258	1
Rack Compressor Distractor	8801046	1
Fulcrum "Pistol" Grip Compressor	8801249	1
Compressor Final Driver	8801250	1
Compressor Left Arm, Short	8801052	1
Compressor Left Arm, Long	8801053	1
Compressor Right Arm, Short	8801054	1
Compressor Right Arm, Long	8801055	1
French Bender	8801026	1
Precept IFU	9401385	1



## CATALOG

### PRECEPT™ LONG CONSTRUCT INSTRUMENTS

DESCRIPTION	CATALOG #	QUANTITY
NuVasive® Tray Lid, Purple	8801300	1
Precept Long Construct Base	8801313	1
Precept Long Construct Screw Level	8801316	1
Precept Lock Screw Caddy	8801107	1
Precept Lock Screw Caddy Lid	8801108	1
Lock Screw	8800000	18
Precept Long Construct 4.5mm Screw Caddy	8801339	1
Precept Polyaxial Screw 4.5 x 25mm	8804525A	2
Precept Polyaxial Screw 4.5 x 30mm	8804530A	4
Precept Polyaxial Screw 4.5 x 35mm	8804535A	4
Precept Polyaxial Screw 4.5 x 40mm	8804540A	2
Precept Polyaxial Screw 4.5 x 45mm	8804545A	2
Precept Long Construct 5.5mm Screw Caddy	8801335A	1
Precept Polyaxial Screw 5.5 x 30mm	8805530A	2
Precept Polyaxial Screw 5.5 x 35mm	8805535A	2
Precept Polyaxial Screw 5.5 x 40mm	8805540A	2
Precept Polyaxial Screw 5.5 x 45mm	8805545A	4
Precept Polyaxial Screw 5.5 x 50mm	8805550A	2
Precept Polyaxial Screw 5.5 x 55mm	8805555A	2
Precept Long Construct 6.5mm Screw Caddy	8801336	1
Precept Polyaxial Screw 6.5 x 30mm	8806530A	2
Precept Polyaxial Screw 6.5 x 35mm	8806535A	2
Precept Polyaxial Screw 6.5 x 40mm	8806540A	4
Precept Polyaxial Screw 6.5 x 45mm	8806545A	6
Precept Polyaxial Screw 6.5 x 50mm	8806550A	4
Precept Polyaxial Screw 6.5 x 55mm	8806555A	2
Precept Long Construct 7.5mm Screw Caddy	8801337	1
Precept Polyaxial Screw 7.5 x 30mm	8807530A	2
Precept Polyaxial Screw 7.5 x 35mm	8807535A	2
Precept Polyaxial Screw 7.5 x 40mm	8807540A	2
Precept Polyaxial Screw 7.5 x 45mm	8807545A	2
Precept Polyaxial Screw 7.5 x 50mm	8807550A	2
Precept Polyaxial Screw 7.5 x 55mm	8807555A	2
Precept Polyaxial Screw 7.5 x 60mm	8807560A	2
Precept Polyaxial Screw 7.5 x 70mm	8807570A	2
Precept Polyaxial Screw 7.5 x 80mm	8807580A	2
Precept Polyaxial Screw 7.5 x 90mm	8807590A	2
Precept Polyaxial Screw 7.5 x 100mm	8807500A	2
Precept Long Construct 8.5mm Screw Caddy	8801338	1
Precept Polyaxial Screw 8.5 x 35mm	8808535A	2

### PRECEPT LONG CONSTRUCT INSTRUMENTS (CONT.)

DESCRIPTION	CATALOG #	QUANTITY
Precept Polyaxial Screw 8.5 x 40mm	8808540A	2
Precept Polyaxial Screw 8.5 x 45mm	8808545A	2
Precept Polyaxial Screw 8.5 x 50mm	8808550A	2
Precept Polyaxial Screw 8.5 x 55mm	8808555A	2
Precept Polyaxial Screw 8.5 x 60mm	8808560A	2
Precept Polyaxial Screw 8.5 x 70mm	8808570A	2
Precept Polyaxial Screw 8.5 x 80mm	8808580A	2
Precept Polyaxial Screw 8.5 x 90mm	8808590A	2
Precept Polyaxial Screw 8.5 x 100mm	8808500A	2
Precept Long Construct Rod Level	8801315	1
Precept Straight Rod 160mm Ti	8848160	2
Precept Straight Rod 170mm Ti	8848170	2
Precept Straight Rod 180mm Ti	8848180	2
Precept Straight Rod 190mm Ti	8848190	2
Precept Straight Rod 200mm Ti	8848200	2
Precept Straight Rod 210mm Ti	8848210	2
Precept Straight Rod 220mm Ti	8848220	2
Precept Straight Rod 230mm Ti	8848230	2
Precept Straight Rod 240mm Ti	8848240	2
Precept Straight Rod 250mm Ti	8848250	2
Precept Straight Rod 300mm Ti	8848300	2
Precept Straight Rod 500mm Ti	8848500	4
Rod Template 500mm	8801028	2
Precept Long Construct Instruments Level	8801314	1
First Insulator	8801203	1
Tap Insulator	8801204	1
Screw Insulator	8801205	1
Standard Guide	8801208	4
Threaded Rod Pusher	8801235	1
"Pile Driver"	8801238	2
Reduction Attachment	8801239	1
Reduction T-handle	8801075	1
Bulldozer	8801074	2
Tap 5.5mm	8801355	1
Tap 6.5mm	8801365	1
Tap 8.5mm	8801385	1
Precept IFU	9401385	1

## CATALOG

### PRECEPT™ CORE IMPLANTS

DESCRIPTION	CATALOG #	QUANTITY
NuVasive® Tray Lid, Purple	8801300	1
Precept Core Implants Base	8801301	1
Precept Core Implants Polyaxial Screw Level	8801303	1
Precept Lock Screw Caddy	8801107	1
Precept Lock Screw Caddy Lid	8801108	1
Precept Lock Screw	8800000	18
Precept Core Implants Polyaxial Screw Caddy	8801304	1
Precept Polyaxial Screw 5.5 x 30mm	8805530A	4
Precept Polyaxial Screw 5.5 x 35mm	8805535A	4
Precept Polyaxial Screw 5.5 x 40mm	8805540A	4
Precept Polyaxial Screw 5.5 x 45mm	8805545A	6
Precept Polyaxial Screw 5.5 x 50mm	8805550A	4
Precept Polyaxial Screw 5.5 x 55mm	8805555A	4
Precept Polyaxial Screw 6.5 x 30mm	8806530A	4
Precept Polyaxial Screw 6.5 x 35mm	8806535A	4
Precept Polyaxial Screw 6.5 x 40mm	8806540A	6
Precept Polyaxial Screw 6.5 x 45mm	8806545A	8
Precept Polyaxial Screw 6.5 x 50mm	8806550A	6
Precept Polyaxial Screw 6.5 x 55mm	8806555A	4
Precept Polyaxial Screw 7.5 x 30mm	8807530A	4
Precept Polyaxial Screw 7.5 x 35mm	8807535A	4
Precept Polyaxial Screw 7.5 x 40mm	8807540A	4
Precept Polyaxial Screw 7.5 x 45mm	8807545A	4
Precept Polyaxial Screw 7.5 x 50mm	8807550A	4
Precept Polyaxial Screw 7.5 x 55mm	8807555A	4
Precept Core Implants Rod Level	8801302	1
Precept Pre-bent Lordotic Rod 20mm Ti	8847020	4
Precept Pre-bent Lordotic Rod 25mm Ti	8847025	4
Precept Pre-bent Lordotic Rod 30mm Ti	8847030	4
Precept Pre-bent Lordotic Rod 35mm Ti	8847035	4
Precept Pre-bent Lordotic Rod 40mm Ti	8847040	4
Precept Pre-bent Lordotic Rod 45mm Ti	8847045	4
Precept Pre-bent Lordotic Rod 50mm Ti	8847050	4
Precept Pre-bent Lordotic Rod 55mm Ti	8847055	4
Precept Pre-bent Lordotic Rod 60mm Ti	8847060	4
Precept Pre-bent Lordotic Rod 65mm Ti	8847065	4
Precept Pre-bent Lordotic Rod 70mm Ti	8847070	4
Precept Pre-bent Lordotic Rod 75mm Ti	8847075	4

### PRECEPT CORE IMPLANTS (CONT.)

DESCRIPTION	CATALOG #	QUANTITY
Precept Pre-bent Lordotic Rod 80mm Ti	8847080	4
Precept Pre-bent Lordotic Rod 85mm Ti	8847085	4
Precept Pre-bent Lordotic Rod 90mm Ti	8847090	4
Precept Pre-bent Lordotic Rod 95mm Ti	8847095	4
Precept Pre-bent Lordotic Rod 100mm Ti	8847100	4
Precept Pre-bent Lordotic Rod 110mm Ti	8847110	4
Precept Pre-bent Lordotic Rod 120mm Ti	8847120	4
Precept Pre-bent Lordotic Rod 130mm Ti	8847130	4
Precept Pre-bent Lordotic Rod 140mm Ti	8847140	4
Precept Pre-bent Lordotic Rod 150mm Ti	8847150	4
Precept Pre-bent Lordotic Rod 160mm Ti	8847160	4
Precept Straight Rod 300mm Ti	8848300	2
Rod Template 250mm	8801027	2
Precept IFU	9401385	1

CATALOG

**PRECEPT™ REDUCTION SCREW TRAY**

DESCRIPTION	CATALOG #	QUANTITY
NuVasive® Tray Lid, Purple	8801300	1
Precept Reduction Screw Base	8801321	1
Precept Reduction Screw Instruments Level	8801322	1
Precept Reduction Screw – Screws Level	8801324	1
Precept Open Lock Screw Caddy	8801107	1
Precept Open Lock Screw Lid	8801108	1
Precept Lock Screw	8800000	18
Precept Reduction Screw, 5.5 x 30mm	8825530	4
Precept Reduction Screw, 5.5 x 35mm	8825535	4
Precept Reduction Screw, 5.5 x 40mm	8825540	4
Precept Reduction Screw, 5.5 x 45mm	8825545	6
Precept Reduction Screw, 5.5 x 50mm	8825550	4
Precept Reduction Screw, 5.5 x 55mm	8825555	4
Precept Reduction Screw, 6.5 x 30mm	8826530	4
Precept Reduction Screw, 6.5 x 35mm	8826535	4
Precept Reduction Screw, 6.5 x 40mm	8826540	6
Precept Reduction Screw, 6.5 x 45mm	8826545	8
Precept Reduction Screw, 6.5 x 50mm	8826550	6
Precept Reduction Screw, 6.5 x 55mm	8826555	4
Precept Reduction Screw, 7.5 x 30mm	8827530	4
Precept Reduction Screw, 7.5 x 35mm	8827535	4
Precept Reduction Screw, 7.5 x 40mm	8827540	4
Precept Reduction Screw, 7.5 x 45mm	8827545	4
Precept Reduction Screw, 7.5 x 50mm	8827550	4
Precept Reduction Screw, 7.5 x 55mm	8827555	4
Reduction Splitting Tool	8801290	1
Reduction Attachment (Top Hat)	8801291	2
Reduction Screw Counter-Torque	8801292	1
Reduction Screw Break-off Tool 1	8801293	1
Reduction Screw Break-off Tool 2	8801294	1
Reduction Screwdriver	8801295	2
Reduction Screw Dilator	8801296	1
Reduction Tap Dilator	8801297	1
Precept IFU	9401385	1

**PRECEPT™ MODULAR TRAY**

DESCRIPTION	CATALOG #	QUANTITY
MAS® TLIF Shankdriver, Posted	3400035	2
Compressor	7771116	1
Lateral Reamer	7771165	1
Precept Lock Screw	8800000	14
Precept Caddy, Open Lock Screw	8801107	1
Precept Lid, Open Lock Screw	8801108	1
Precept Open Counter-Torque	8801298	1
Generic NuVasive Tray Lid	8801300	1
Precept Caddy, Polyaxial Screw	8801304	1
Precept Inserter Modular Head	8802004	2
Precept Screw, 5.5 x 30mm – Polyaxial	8805530A	4
Precept Screw, 5.5 x 35mm – Polyaxial	8805535A	4
Precept Screw, 5.5 x 40mm – Polyaxial	8805540A	4
Precept Screw, 5.5 x 45mm – Polyaxial	8805545A	5
Precept Screw, 5.5 x 50mm – Polyaxial	8805550A	4
Precept Screw, 5.5 x 55mm – Polyaxial	8805555A	4
Precept Screw, 6.5 x 30mm – Polyaxial	8806530A	4
Precept Screw, 6.5 x 35mm – Polyaxial	8806535A	4
Precept Screw, 6.5 x 40mm – Polyaxial	8806540A	4
Precept Screw, 6.5 x 45mm – Polyaxial	8806545A	5
Precept Screw, 6.5 x 50mm – Polyaxial	8806550A	4
Precept Screw, 6.5 x 55mm – Polyaxial	8806555A	4
Precept Screw, 7.5 x 30mm – Polyaxial	8807530A	4
Precept Screw, 7.5 x 35mm – Polyaxial	8807535A	4
Precept Screw, 7.5 x 40mm – Polyaxial	8807540A	4
Precept Screw, 7.5 x 45mm – Polyaxial	8807545A	4
Precept Screw, 7.5 x 50mm – Polyaxial	8807550A	4
Precept Screw, 7.5 x 55mm – Polyaxial	8807555A	3
Precept Ti Rod, 20mm – Pre-bent Lordotic	8847020	3
Precept Ti Rod, 25mm – Pre-bent Lordotic	8847025	3
Precept Ti Rod, 30mm – Pre-bent Lordotic	8847030	3
Precept Ti Rod, 35mm – Pre-bent Lordotic	8847035	3
Precept Ti Rod, 40mm – Pre-bent Lordotic	8847040	3
Precept Ti Rod, 45mm – Pre-bent Lordotic	8847045	3
Precept Ti Rod, 50mm – Pre-bent Lordotic	8847050	3
Precept Ti Rod, 55mm – Pre-bent Lordotic	8847055	3
Precept Ti Rod, 60mm – Pre-bent Lordotic	8847060	3
Precept Ti Rod, 65mm – Pre-bent Lordotic	8847065	3

**CATALOG**
**PRECEPT™ MODULAR TRAY (CONT.)**

DESCRIPTION	CATALOG #	QUANTITY
Precept Ti Rod, 70mm – Pre-bent Lordotic	8847070	3
Precept Ti Rod, 75mm – Pre-bent Lordotic	8847075	3
Precept Ti Rod, 80mm – Pre-bent Lordotic	8847080	3
Precept Ti Rod, 85mm – Pre-bent Lordotic	8847085	3
Precept Ti Rod, 90mm – Pre-bent Lordotic	8847090	3
Precept Ti Rod, 150mm – Pre-bent Lordotic	8847150	3
Precept Ti Rod, 300mm – Straight	8848300	2
Precept Modular Tulip	8890000	8
Precept Modular Tulip Caddy	8890001	1
Precept Modular Tulip Caddy Lid	8890002	1
Precept Modular Base Tray	8890003	1
Precept Modular Middle Tray	8890004	1
Precept Modular Bottom Tray	8890005	1
Precept Modular Top Tray	8890006	1
Precept Modular Shank Caddy	8890007	1
Precept Modular Tag, Large	8890012	1
Precept Modular Tag, Small	8890013	1
Precept Dilator, Modular Primary	8890022	1
Precept Screw Shank, 5.5 x 30mm – Modular	8895530	3
Precept Screw Shank, 5.5 x 35mm – Modular	8895535	3
Precept Screw Shank, 5.5 x 40mm – Modular	8895540	4
Precept Screw Shank, 5.5 x 45mm – Modular	8895545	4
Precept Screw Shank, 5.5 x 50mm – Modular	8895550	4
Precept Screw Shank, 5.5 x 55mm – Modular	8895555	3
Precept Screw Shank, 6.5 x 30mm – Modular	8896530	3
Precept Screw Shank, 6.5 x 35mm – Modular	8896535	3
Precept Screw Shank, 6.5 x 40mm – Modular	8896540	4
Precept Screw Shank, 6.5 x 45mm – Modular	8896545	4
Precept Screw Shank, 6.5 x 50mm – Modular	8896550	4
Precept Screw Shank, 6.5 x 55mm – Modular	8896555	3
Precept Screw Shank, 7.5 x 30mm – Modular	8897530	3
Precept Screw Shank, 7.5 x 35mm – Modular	8897535	3
Precept Screw Shank, 7.5 x 40mm – Modular	8897540	4
Precept Screw Shank, 7.5 x 45mm – Modular	8897545	4
Precept Screw Shank, 7.5 x 50mm – Modular	8897550	4
Precept Screw Shank, 7.5 x 55mm – Modular	8897555	3

## INSTRUCTIONS FOR USE

### DESCRIPTION

The NuVasive® Precept™ Spinal System consists of a series of polyaxial screws, reduction screws, rods and lock screws manufactured from Ti-6Al-4V per ASTM F-136 and ISO 5832-3 or cobalt chromium per ASTM F1537.

### INDICATIONS

When used as a pedicle screw fixation system, the NuVasive Precept Spinal System is intended to provide immobilization and stabilization of spinal segments in skeletally mature patients as an adjunct to fusion in the treatment of the following acute and chronic instabilities or deformities of the posterior thoracic, lumbar, and sacral spine:

1. Degenerative disc disease (as defined by back pain of discogenic origin with degeneration of the disc confirmed by patient history and radiographic studies)
2. Degenerative spondylolisthesis with objective evidence of neurologic impairment
3. Fracture
4. Dislocation
5. Scoliosis
6. Kyphosis
7. Spinal tumor and/or
8. Failed previous fusion (pseudoarthrosis)

The NuVasive Precept Spinal System is also indicated for the treatment of severe spondylolisthesis (Grades 3 and 4) of the L5-S1 vertebral joint in skeletally mature patients receiving fusion by autogenous bone graft, having the device fixed or attached to the lumbar and sacral spine (L3 to sacrum), with removal of the implants after attainment of a solid fusion.

When used as an anterolateral non-pedicle screw system in the thoracic and lumbar spine, the NuVasive Precept Spinal System is also intended for the following indications:

1. Degenerative disc disease (as defined by back pain of discogenic origin with degeneration of the disc confirmed by patient history and radiographic studies)
2. Spinal stenosis
3. Spondylolisthesis
4. Spinal deformities
5. Fracture
6. Pseudoarthrosis
7. Tumor resection and/or
8. Failed previous fusion

### CONTRAINDICATIONS

Contraindications include but are not limited to:

1. Infection, local to the operative site.
2. Signs of local inflammation.
3. Patients with known sensitivity to the materials implanted.
4. Patients who are unwilling to restrict activities or follow medical advice.
5. Patients with inadequate bone stock or quality.
6. Patients with physical or medical conditions that would prohibit beneficial surgical outcome.
7. Use with components of other systems.
8. Reuse or multiple use.
9. Any case not described in the indications.

### POTENTIAL ADVERSE EVENTS AND COMPLICATIONS

As with any major surgical procedures, there are risks involved in orthopedic surgery. Infrequent operative and postoperative complications known to occur include: early or late infection which may result in the need for additional surgeries; damage to blood vessels; spinal cord or peripheral nerves; pulmonary emboli; loss of sensory and/or motor function; impotence; permanent pain and/or deformity. Rarely, some complications may be fatal.

### WARNINGS, CAUTIONS AND PRECAUTIONS

The subject device is intended for use only as indicated.

The safety and effectiveness of pedicle screw spinal systems have been established only for spinal conditions with significant mechanical instability or deformity requiring fusion with instrumentation. These conditions are significant mechanical instability or deformity of the thoracic, lumbar, and sacral spine secondary to severe spondylolisthesis (grades 3 and 4) of the L5-S1 vertebra, degenerative spondylolisthesis with objective evidence of neurologic impairment, fracture, dislocation, scoliosis, kyphosis, spinal tumor, and failed previous fusion (pseudoarthrosis). The safety and effectiveness of these devices for any other conditions are unknown.

The implantation of pedicle screw spinal systems should be performed only by experienced spinal surgeons with specific training in the use of this pedicle screw spinal system because this is a technically demanding procedure presenting a risk of serious injury to the patient.

Benefit of spinal fusions utilizing any pedicle screw fixation system has not been adequately established in patients with stable spines.

Potential risks identified with the use of this device system, which may require additional surgery, include: device component fracture, loss of fixation, non-union, fracture of the vertebra, neurological injury, and vascular or visceral injury.

Correct selection of the implant is extremely important. The potential for success is increased by the selection of the proper size of the implant. While proper selection can minimize risks, the size and shape of human bones present limitations on the size and strength of implants. Metallic internal fixation devices cannot withstand the activity levels and/or loads equal to those placed on normal, healthy bone. These devices are not designed to withstand the unsupported stress of full weight or load bearing alone.

Caution must be taken due to potential patient sensitivity to materials. Do not implant in patients with known or suspected sensitivity to the aforementioned materials.

These devices can break when subjected to the increased load associated with delayed union or non-union. Internal fixation appliances are load-sharing devices that hold bony structures in alignment until healing occurs. If healing is delayed, or does not occur, the implant may eventually loosen, bend, or break. Loads on the device produced by load bearing and by the patient's activity level will dictate the longevity of the implant.

Corrosion of the implant can occur. Implanting metals and alloys in the human body subjects them to a constantly changing environment of salts, acids, and alkalis, which can cause corrosion. Placing dissimilar metals in contact with each other can accelerate the corrosion process, which in turn, can enhance fatigue fractures of implants. Consequently, every effort should be made to use compatible metals and alloys in conjunction with each other.

Care should be taken to insure that all components are ideally fixated prior to closure.

All implants should be used only with the appropriately designated instrument (Reference Surgical Technique).

All set screws should be final-tightened with the Counter-Torque and Torque T-Handle.

Do not final-tighten through other instruments in the set, as the rod may not be able to normalize to the tulip.

Do not final-tighten through the fulcrum compressor, as the rod may not have the freedom to normalize to the tulip.

Do not final-tighten through the Rack Compressor Distractor, as the rod may not have the freedom to normalize to the tulip.

Do not final-tighten through the single-level reducer, as the rod may not have the freedom to normalize to the tulip.

Ensure the Guide is perpendicular to the rod when reducing with the "Pile Driver."

The Screw Dilator cannot be used to sequentially dilate around the Tap-Dilator Combo. Therefore, the screw will be inserted without a dilator.

Use lateral fluoroscopy to properly manage the K-Wire during pedicle preparation to ensure proper placement and avoid anterior advancement of the K-Wire.

## INSTRUCTIONS FOR USE

**SINGLE USE:** Reuse of a single use device that has come in contact with blood, bone, tissue or other body fluids may lead to patient or user injury. Possible risks associated with reuse of a single use device include, but are not limited to, mechanical failure, material degradation, potential leachables, and transmission of infectious agents. Resterilization may result in damage or decreased performance.

**PATIENT EDUCATION:** Preoperative instructions to the patient are essential. The patient should be made aware of the limitations of the implant and potential risks of the surgery. The patient should be instructed to limit postoperative activity, as this will reduce the risk of bent, broken or loose implant components. The patient must be made aware that implant components may bend, break or loosen even though restrictions in activity are followed.

**MAGNETIC RESONANCE (MR) SAFETY:** The Precept™ Spinal System has not been evaluated for safety and compatibility in the MR environment. The Precept Spinal System has not been tested for heating or migration in the MR environment.

**COMPATIBILITY:** Do not use Precept Spinal System with components of other systems. Unless stated otherwise, NuVasive devices are not to be combined with the components of another system.

### PREOPERATIVE WARNINGS

1. Only patients that meet the criteria described in the indications should be selected.
2. Patient condition and/or predispositions such as those addressed in the aforementioned contraindications should be avoided.
3. Care should be used in the handling and storage of the implants. The implants should not be scratched or damaged. Implants and instruments should be protected during storage, and from corrosive environments.
4. All non-sterile parts should be cleaned and sterilized before use.
5. Devices should be inspected for damage prior to implantation.
6. Care should be used during surgical procedures to prevent damage to the device(s) and injury to the patient.

### POST-OPERATIVE WARNINGS

During the postoperative phase it is of particular importance that the physician keeps the patient well informed of all procedures and treatments.

Damage to the weight-bearing structures can give rise to loosening of the components, dislocation and migration as well as to other complications. To ensure the earliest possible detection of such catalysts of device dysfunction, the devices must be checked periodically postoperatively, using appropriate radiographic techniques.











To order, please contact your NuVasive® Sales Consultant or Customer Service Representative today at:  
**NuVasive, Inc.** 7475 Lusk Blvd., San Diego, CA 92121 USA • phone: 800-475-9131 fax: 800-475-9134  
**NuVasive UK Ltd.** Suite B, Ground Floor, Caspian House, The Waterfront, Elstree, Herts WD6 3BS UK

EC	REP
----	-----

 phone: +44 (0) 208-238-7850 fax: +44 (0) 207-998-7818

[www.nuvasive.com](http://www.nuvasive.com)

©2013. NuVasive, Inc. All rights reserved.  NuVasive, Speed of Innovation, MAS, and NVM5 are registered trademarks of NuVasive, Inc. I-PAS and Precept are trademarks of NuVasive, Inc.

9500890 E

